

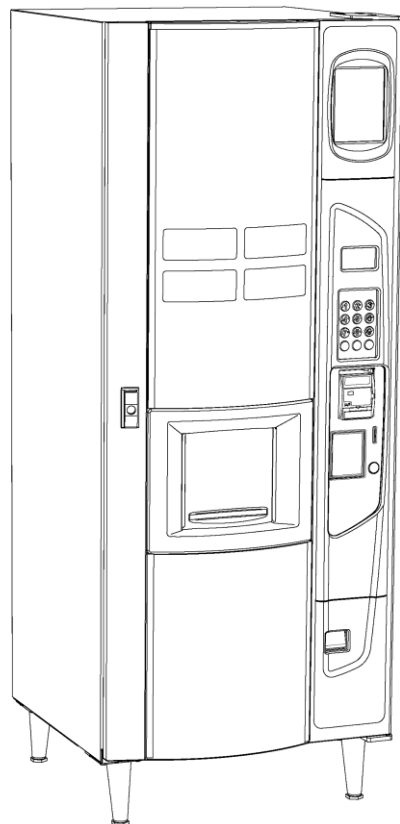

# **GENEVA HOT BEVERAGE MERCHANTISER**



## **SERVICE MANUAL**

### **MODELS**

**3205 FRESH BREW  
3206 FREEZE DRIED  
3211 BEAN TO CUP**



INTRODUCTION.....	1	Chocolate.....	48
SPECIFICATIONS.....	1	French Vanilla Capp.....	49
SAFETY WARNINGS.....	2	English Toffee.....	50
AMERICANS WITH DISABILITIES ACT (ADA).....	2	Tea.....	51
MACHINE PARTS.....	3	Chai Tea / Latte.....	52
INSTALLATION.....	4	Set Date and Time.....	53
Installation Checklist.....	6	Set Pricing Mode.....	53
Instructions for the ADA monetary area.....	7	Change Prices.....	53
Installing a coin changer.....	7	Inhibit Drink.....	53
FILL PRODUCT CANISTERS.....	9	Alter Drink Name.....	53
CHANGE MENU SELECTION LABELS.....	10	Timed Activities.....	54
CUP SIZE ADJUSTMENT.....	11	Temperature Settings.....	55
Set price for single drink volume (large).....	12	Output Test.....	55
Set prices for dual drink volumes (Reg & Large).....	13	Input Test.....	55
FILL CUP COMPARTMENT.....	14	Machine Status.....	56
CUP SIZE ADJUSTMENT.....	15	Set Dry Vends.....	56
FLUSH HEATER TANK, BOWL & BREWER.....	16	Serial Number.....	56
DRIP CATCHER.....	17	Configure Machine.....	57
GENERAL DESCRIPTION.....	18	General Settings.....	57
Cabinet Front.....	18	Set drink sizes.....	58
Cabinet Rear.....	18	Set Machine Type.....	58
Water System.....	18	Set Cup size.....	59
Hot Water System.....	18	Set Cash System.....	59
Internal Keypad Functions.....	22	Hardware Settings.....	59
VIEWING COUNTER & EVENT RECORDS.....	24	MDB Config.....	60
Heading Menu's List.....	24	EVA-DTS CONFIG.....	62
Available Sub-menu's.....	24	Previous Audit.....	62
TAKING A TEST VEND.....	25	Method of Audit.....	62
DIAGNOSTIC LOG.....	25	Audit Config.....	62
PROGRAMMING.....	26	Product Codes.....	62
Accessing the User Programs.....	26	Operator Code.....	62
User Keypad.....	27	Manager Code.....	62
Program Functions.....	28	Engineer Code.....	62
Programming Sequence Of Operations.....	29	Free Drink Code.....	62
Menu Options.....	30	Edit Drink Map.....	63
Ingredient Times.....	30	Card Actions.....	63
Bean To Cup Recipe Chart (S/w Rev >36E).....	31	Editable Text.....	65
Fresh Brew Recipe Chart (S/w Rev >29E).....	33	Depressurize Coffee Brewer.....	66
Fresh Brew Cofee.....	33	<b>COFFEE BREWER.....</b>	<b>67</b>
Whipped Coffee (Fresh Brew).....	36	Coffee Brewer Operation.....	67
Whipped Decaf (Fresh Brew).....	37	<b>BEAN TO CUP.....</b>	<b>68</b>
Fresh Brew Decaf Coffee.....	38	Set-up.....	68
Espresso (Fresh Brew Coffee).....	40	Bean Grinder Schematic.....	70
Café Mocha (Fresh Brew Coffee).....	42	<b>TROUBLESHOOTING GUIDELINES.....</b>	<b>71</b>
Cappuccino (Fresh Brew Coffee).....	44	<b>REPLACEMENT CONTROL BOARD SET-UP ...</b>	<b>73</b>
Café Latte (Fresh Brew Coffee).....	46	<b>NOTES:.....</b>	<b>74</b>

The Model and Serial numbers are needed for you to obtain quick service and parts information for your machine. The numbers are given on the identification plate located on the back side of the cabinet of the machine.

MODEL NUMBER: \_\_\_\_\_

SERIAL NUMBER: \_\_\_\_\_

## INTRODUCTION

1. The information contained in this service manual is applicable to the Hot Beverage Merchandiser. The Hot Beverage Merchandiser model consists of three model types of coin-operated, microprocessor controlled, Hot Beverage Merchandiser that dispense a range of hot drinks in response to keypad selections.
2. Three model versions are available:
  - ▶ Bean To Cup – Whole Bean Coffee
  - ▶ Fresh Brew (SFB) - Loose Ground Coffee
  - ▶ Instant (INST) - Soluble/Instant Coffee and Tea
3. This manual uses the SFB version as the basis for examples. Where significant differences between versions exist this will be highlighted in the main body of the document. Due to customer requirements, however, some features may vary from those described, e.g. extras fitted, variations in programming etc.
4. Cups from a cup drop mechanism are dispensed to contain the drinks.
5. Selection is made on a 12 button keypad and a Vacuum Fluorescent display panel shows status and drink selection information.
6. The status of the machine may be monitored and the configuration altered by accessing a menu of program options using both internal and external keypads. Each option comprises a number of sub-options, the settings of which can be altered.
7. A feature of the Hot Beverage Merchandiser is the moving dispensing manifold which moves the head to a 'parked' and a 'hot water' dispense position this rinses the cup station tray during flush cycles and prevents the possibility of cross-contamination of clear hot water drinks.
8. Hot Beverage Merchandiser machines require a single-phase 120V electrical mains supply from a domestic 12A outlet, and a cold water supply from the domestic cold water main. These services enter the machine at the rear of the cabinet.
9. Maintenance of the coffee machine must only be undertaken by personnel who are authorized, suitably qualified and are fit & well to do so.
10. The contents of this publication are presented for informational purposes only, and while every effort has been made to ensure their accuracy, they are not to be construed as warranties or guarantees, express or implied, regarding the products or services described herein or their use or applicability. We reserve the right to modify or improve the designs or specifications of such products at any time without notice.

## SPECIFICATIONS

### DIMENSIONS

**HEIGHT:** 72 inches (1830 mm)  
**DEPTH:** 28 inches (711 mm)  
**WIDTH:** 27.75 inches (705 mm)

### SHIPPING WEIGHT

360 lbs (163 kg) – Fresh Brew version

### ELECTRICAL

120 Volts, 60 Hz, 9.2 Amps nominal  
240 Volts, 50 Hz, 13 Amps

### CUP CAPACITY

**QUANTITY:** Up to 400 (7oz) cups  
**SIZES:** 7 oz, 8 ¼ oz, 9 oz, 10 oz & 12 oz

### OPERATING ENVIRONMENT

**LOCATION:** For indoor use only.  
**SOUND LEVEL:** Produces less than 70dBA during normal operation  
**TEMPERATURE:** 46°F (8°C) to 90°F (32°C)

## SAFETY WARNINGS

1. **DISCONNECT OR UNPLUG POWER TO THE MACHINE BEFORE SERVICING.** Potentially lethal voltages are exposed when any panel inside the cabinet is removed and power is supplied to the on/off switch.
2. Installation and maintenance of the Hot Beverage Merchandiser is only to be undertaken by trained personnel who are fully aware of the dangers involved and who have taken adequate precautions.
3. The Hot Beverage Merchandiser must be grounded (earthed). Do not tamper, modify or remove the ground pin from the power plug. Should the power cord or plug become damaged, a trained person from approved service agent must perform the replacement using only factory approved parts. Do not ground (earth) the machine to the mains water supply pipe.
4. Keep clear of the Brewer Unit when it is operating.
5. The Hot Beverage Merchandiser is a heavy item. Ensure that sufficient personnel are available for lifting and transporting of the machine. Use proper lifting procedures and equipment.
6. The water in the heater tank and the tank itself are hot enough to scald or burn even some time after the machine has been switched off. The water tank must be drained, filled with cold water and drained again before any attempt is made to handle it or any of its associated parts.
7. The Controller Board is fitted with a lithium battery. Abuse of this type of battery can lead to overheating, venting, explosion, release of potentially hazardous materials and spontaneous ignition.  
The lithium battery **must not** be charged or connected to any other source of power. The battery **must not** be short-circuited or forced to discharge its stored energy. The battery **must not** be subjected to physical damage or overheating. If the Controller Board is to be replaced, it must be handled with care, taking all practical anti-static precautions.
8. Care must be taken to protect the Hot Beverage Merchandiser from frost. Do not attempt to operate the machine if it becomes frozen. Contact the nearest service agent immediately. Do not restore the machine to operation use until it has been checked and approved for use by the service agent.
9. Young children, the aged and the infirm should not be allowed to operate the Hot Beverage Merchandiser unsupervised, in order to protect them from the risk of being scalded by hot beverages.

**IMPORTANT:** Please refer to the safety manual p/n 4206816 for additional safety information.

## AMERICANS WITH DISABILITIES ACT (ADA)

Vending operators serving "public entities," meaning government locations and locations accessible to the public, must meet new reach requirements of the law beginning March 15, 2012, under the Americans with Disabilities Act (ADA).

The regulations establish side reach regulations requiring that all operable parts of the vending machine be no higher than 48 inches and no lower than 15 inches. This differs from the 1991 standards which have controls at 54 inches high and nine inches low. The Geneva Coffee machine fully complies with these regulations.

# MACHINE PARTS

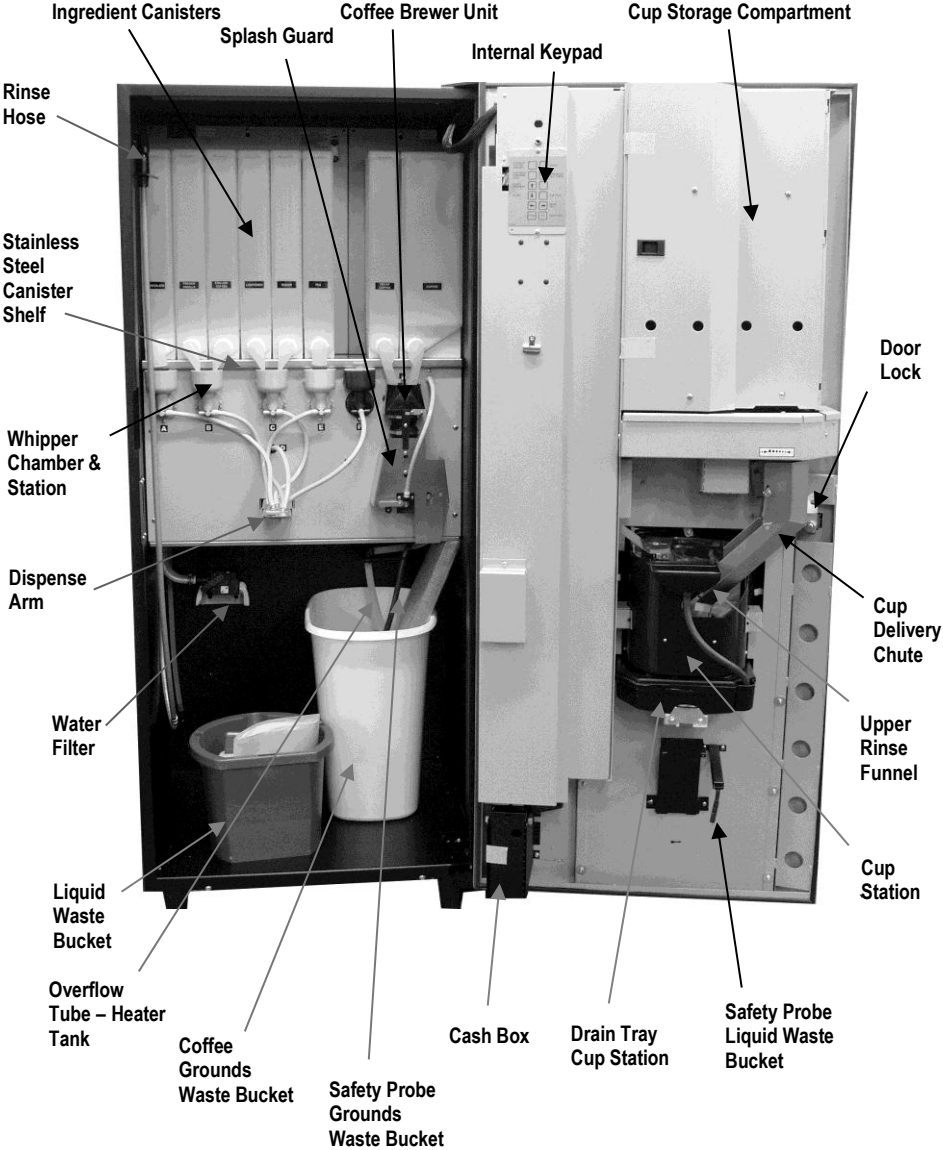

## INSTALLATION

**WARNING:** Disconnect or unplug power to the machine before servicing.

1. Servicing personnel must be familiar with the SAFETY WARNINGS listed in this manual and the Safety Manual (P/N 4206816) before undertaking any installation or maintenance procedure on the Hot Beverage Merchandiser. Any procedure which is found to be impracticable, inadequate or inaccurate should be reported to the Management for further investigation.
2. The information given in this section covers installation and maintenance procedures for the Hot Beverage Merchandiser. Authorized personnel who have knowledge or experience with the equipment using only the manufacturers' approved parts must carry out these procedures.
3. The requirements of proper hygiene in respect of food products must be ensured at every level of contact with the Hot Beverage Merchandiser and the ingredients associated with it.

## REQUIREMENTS

### Electrical Supply

- 110V, 60Hz, 12A fused  
**OR**
- 240V, 50Hz, 13A fused

The electrical outlet and supply circuit must be dedicated and isolated before connecting the power to the machine. The electrical outlet must be within 6 ft (2 m) of the machine. Preferably, the switched outlet should be located behind the machine to prevent accidental damage or misuse.

### Water Supply

The main water supply must have 15-116 psi (1-8 Bar) pressure. The water outlet must have a shutoff valve to disconnect the water supply during servicing. It must have a long enough water supply hose with a 3/8" flare or 1/4" NPT connector to reach the machine. If possible, the water outlet should be located behind the machine to prevent misuse.

## LOCATION

**WARNING:** The Hot Beverage Merchandiser is a heavy item. Ensure that sufficient personnel are available for lifting and transporting the machine. Use proper lifting procedures and equipment.

The Hot Beverage Merchandiser must be located close to the appropriate electrical and water outlets.

There must be a minimum of 4" inch (100mm) clearance between the rear of the cabinet and the wall to allow adequate ventilation. See **Figure 4a**.

If placing in a corner location, there must be at least 16" inches (406mm) of space to the right hand wall to allow for opening the door.

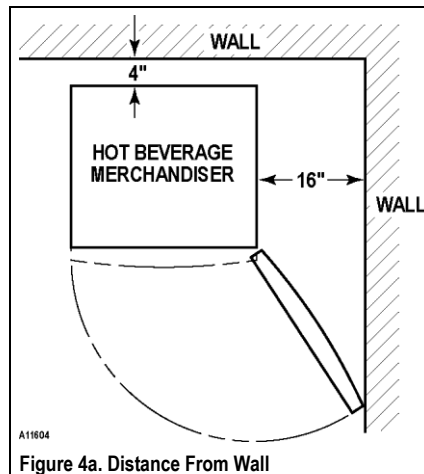

**Figure 4a. Distance From Wall**

## LEVELING

The Hot Beverage Merchandiser must be level for the machine to operate properly. Use a level as a guide and turn the machine's leg levelers as needed so that all levelers are touching the floor. If it is properly leveled, it should not "rock" or "teeter" on any of the levelers.

When the machine is level, the door can be opened to any position and not move by itself. Try the door at various open positions before deciding that the machine is leveled.

### **CONNECT WATER**

Before connecting the water supply hose to the machine, flush the system via the shutoff valve to remove any impurities which may have accumulated in the water supply pipe or water hose.

Located on the back of the machine is the machine's water inlet – 1/4" NPT Fitting. Remove the plastic protective cap. See **Figure 4b**. There is also a 3/8" Flare Fitting supplied with the machine, if this is preferred.

Connect the water supply hose to machine water inlet and ensure that all fittings are tight. Turn on the water supply at the shutoff valve and check for leaks both behind and inside the machine.

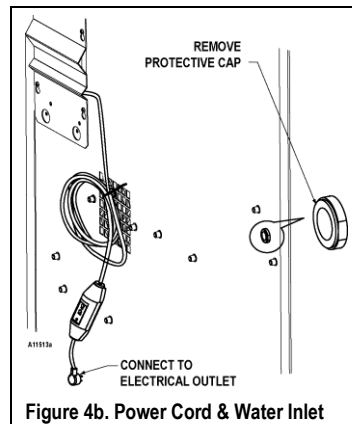

**Figure 4b. Power Cord & Water Inlet**

## **CONNECT ELECTRICAL**

The Hot Beverage Merchandiser power cord is fitted with a GFCI 12A power cord and is connected as follows:

- ▶ GREEN or GREEN/YELLOW wire to EARTH terminal (E).
- ▶ WHITE wire to the NEUTRAL terminal (N).
- ▶ BLACK wire to the LIVE terminal (L).

Connect the mains cable plug to a switch 110V, 60Hz, 12A (240V, 50Hz, 13A) supply socket. With the plug fitted to the socket, ensure that the cable is not being stretched, distorted or fouled.

## **INSTALLATION CHECKLIST**

It is essential that the technician responsible for installing and commissioning the machine ensures the following:

1. All electrical and water supplies are correctly and safely connected.
2. All covers, panels or access doors are in place and secured, and the machine is left in a SAFE condition.
3. The Operator is familiar with the SAFETY PRECAUTIONS for the machine.
4. The importance of hygiene and regular cleaning is fully appreciated by the Operator.

With the water and electrical supplies available to the machine, check the operation of the water heater as follows:

1. Disconnect or unplug power to the machine.
2. Open the cabinet door and check that the on/off switch is in the OFF position.
3. Remove the ingredient canisters and back panels.
4. Ensure that the water heater overflow pipe is not trapped or pinched.
5. Restore the electrical supply to the machine.
6. Using the main switch, set to the ON position.
7. Check that the water heater fills with water and that the water supply cuts off when the correct level is reached, i.e. no water overflows into the waste bucket. Ensure that the waste level probe is located in the waste basket.
8. Set the main switch to the OFF position.

## INSTRUCTIONS FOR THE ADA MONETARY AREA

### INSTALLING A COIN CHANGER

- 1) Mount the changer unit onto the 3 screws provided (see **fig.1a**) and then secure.  
NOTE: Most units should be mounted using the center set of holes. Check the alignment between the coin entry chute and the entry hopper on the unit to determine the best alignment, use the LH or RH mounting holes if needed.
- 2) Check the relationship between the underside of the coin changer and the top surface of the coin cup area, ensure there is a clearance of approximately 3/16" between them; pull the coin unit out/in to ensure there is no interference between the underside of the coin mechanism and the coin cup deflector. Adjust the coin unit mounting assembly up/down by slackening/tightening the nuts shown in **fig.1b**.
- 3) Check the relationship between the underside of the coin entry chute and the top surface of the coin entry hopper to ensure there is minimum clearance between them. Insert the largest and smallest physical coins to verify there is clear passage. Adjust the coin entry chute up/down by slackening/tightening the nuts shown in **fig.2**. Also consider the adjustment in Step 1 which may provide a better solution.
- 4) With the machine switched ON and the coin changer housing pushed firmly home, push the coin return button to check the operation of the coin return motor (see **fig.2**). Ensure that the reject lever on the coin mechanism is actuated sufficiently to clear bent coins. If the stroke of the coin return roller arm needs to be increased/decreased, adjust by slackening/tightening the screws shown in **fig.3**.

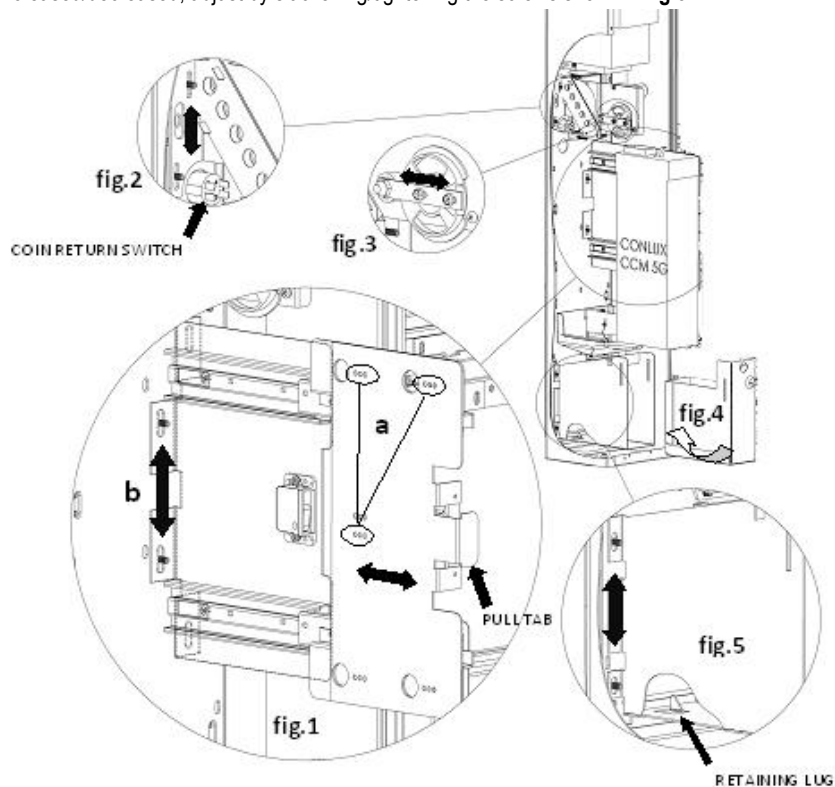

## CASH BOX

- 1) To remove the cash box tilt the box slightly upwards (see **fig.4**) at the front to disengage it from the retaining lug on the floor (see **fig.5**) of the housing before attempting to slide it out.
- 2) When returning the cash box again tilt it slightly upwards at the front and when pushed full-in allow the cash box to sit down and ensure the retaining lug has engaged by pulling/tugging on the box without lifting.

### **IMPORTANT:**

1. **Ensure that the coin unit is pushed fully home after servicing, a positive 'click' will be felt when this is achieved. Failure to do this will result in coins becoming jammed etc.**
2. **DO NOT attempt to close the main door when the coin unit is pulled-out.**
3. **Ensure the cash box is located fully into its housing before closing the main door.**

## FILL PRODUCT CANISTERS

**WARNING: FILL PRODUCT CANISTERS ONLY WITH POWDERED INGREDIENTS. DO NOT USE LIQUID INGREDIENTS.**

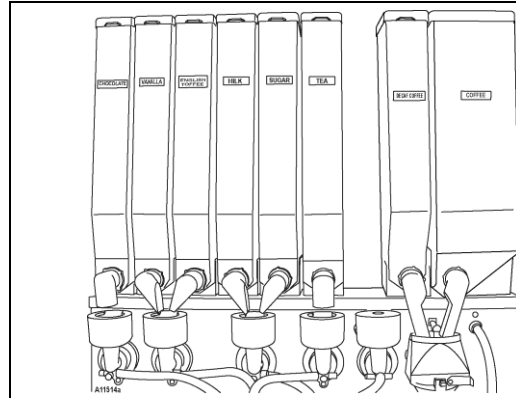

Figure 5a. Canister Lineup

1. Rotate the product chute so that it points up (loading position). See **Figure 5b**.
2. If installing the canisters for the first time, go to step 3. If refilling the canisters, hold the top and bottom of the canister and slowly lift it up so that the locator peg clears the peg hole. **Figure 5c**. Slowly slide the canister forward until it is out of the ingredient motor shaft. **Figure 5d**.
3. Place the canister on a sheet of paper or in a place that can be cleaned easily.
4. Remove the lid from the canister. **Figure 5e**.
5. Take the product bag that matches with the name on the Canister Label (where applicable) and open it according to the instructions on the bag.
6. Slowly pour the product into the canister until the canister is almost full. **Figure 5f**.
  - Product must be loose for product to dispense properly.
  - **DO NOT** tap the sides of the canister.
  - **DO NOT** compress or compact the product into the canister.
  - Leave a gap from the top of the product to the lip of the canister. **Figure 5g**.
7. Place the lid on the canister. **Figure 5e**.
8. Review the canister arranged as shown in **Figure 5a**. Hold the canister carefully at the bottom and top to prevent spilling. Gently place the filled canister back on the product shelf. **Figure 5d**.
9. Line up the hollow shaft behind the canister with the ingredient motor shaft. See **Figure 5d**.
10. Slowly slide the canister towards the motor shaft until the locator peg falls inside the hole on the product shelf. See **Figure 5c**.

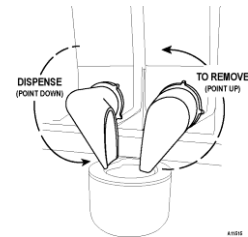

Figure 5b. Product Chute

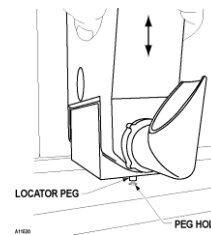

Figure 5c. Locator Peg

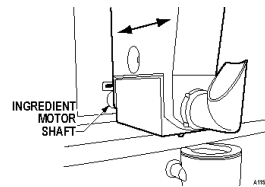

Figure 5d. Motor Shaft

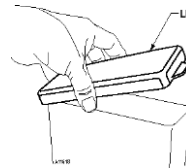

Figure 5e. Canister Lid

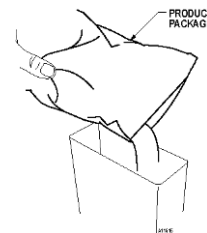
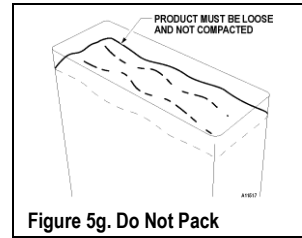

Figure 5f. Fill Canister

11. Rotate the product chute so that it points down (dispense position) to the whipper bowl. See **Figure 5e**.
12. Repeat above steps for all other canisters.



**Figure 5g. Do Not Pack**

## CHANGE MENU SELECTION LABELS

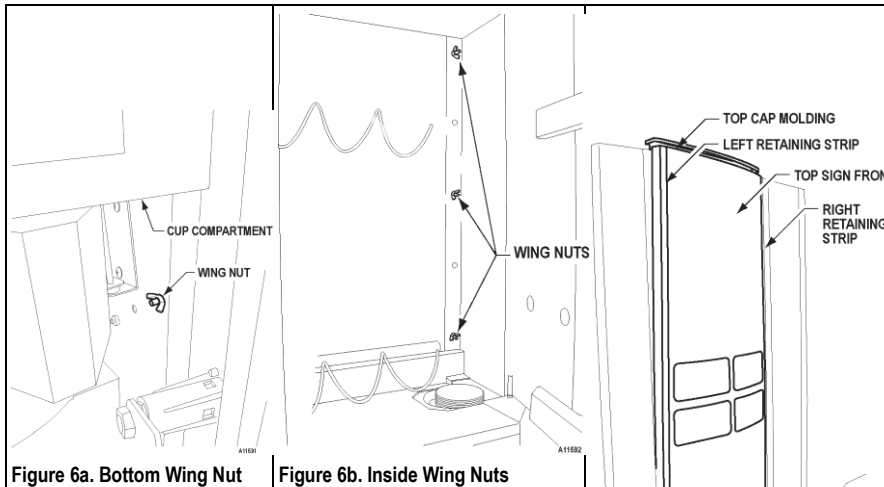

**Figure 6a. Bottom Wing Nut**

**Figure 6b. Inside Wing Nuts**

1. Remove and save the wing nut located on the right side below the cup compartment (as viewed from behind the door). See **Figure 6a**.
2. Open the cup compartment door. Remove and save the wing nuts located on the right corner of the cup compartment. Loosen the 2 wing nut holding Top Cap molding. See **Figure 6b**.

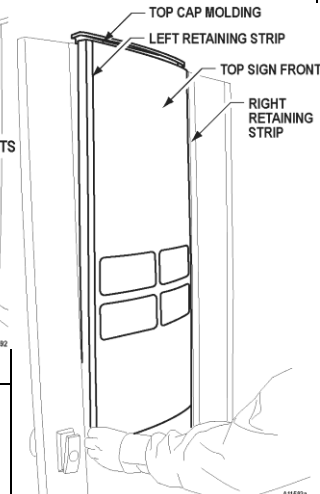

**Figure 6c. Remove Top Sign Front**

3. Go to the front of the cabinet door, lift Top Cap Molding and loosen the Retaining Strip located on the left side of the Top Sign Front. Remove and save the Retaining Strip and Top Sign Front. See **Figure 6c**.
4. Place the Top Sign Front on a clean and non-scratching surface.
5. Locate the menu selection label from behind the Top Sign Front. See **Figure 6d**. Carefully slide the menu selection label out of the pocket and slowly pull on the exposed tab.

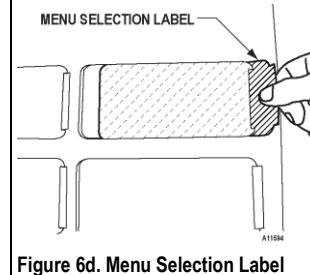
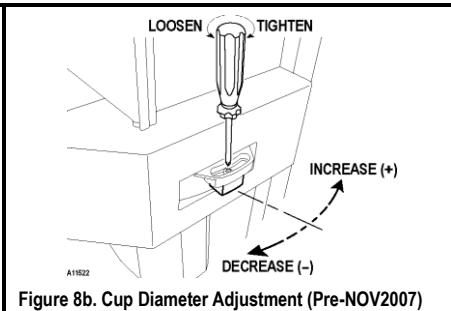
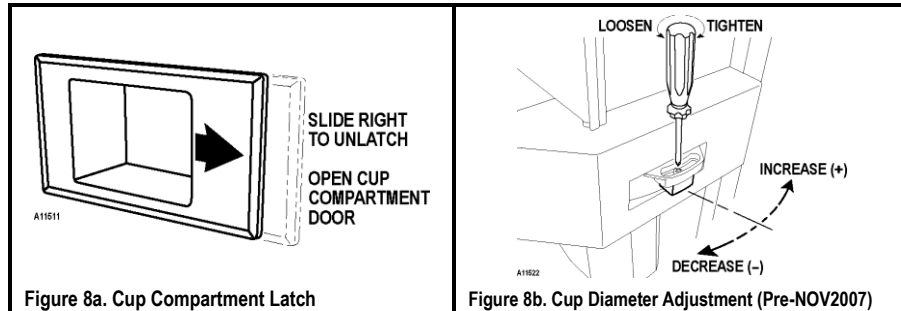

**Figure 6d. Menu Selection Label**

6. Insert the new menu selection label through the slots. Check the front of the Top Sign Front to make sure that the menu selection labels are correctly aligned.
7. Insert the right edge of the Top Sign Front through the slot of the right side Retaining Strip. See **Figure 6c**.
8. Slip the left side Retaining Strip over the left edge of the Top Sign Front. Push the Retaining Strip back into place. See **Figure 6c**.
9. Reinstall and tighten the wing nuts saved from steps 1 and 2. See **Figure 6a** and **Figure 6b**.

## CUP SIZE ADJUSTMENT

The cup mechanism has been factory adjusted for a 12oz cup.  
Follow the instructions below to adjust the cup (diameter) size.



1. Unlock the cup compartment door by sliding the plastic latch to the right. See **Figure 8a**. Open the cup compartment door.
2. Take a cup from the stack of cups that will be used in the machine and place the cup in the cup dispenser ring.
3. While facing the back of the door, find the cup dispenser adjustment screw located on the right side of the cup dispenser. Use a Phillips screwdriver to loosen the screw. DO NOT remove the screw. See **Figure 8c & 8c**.

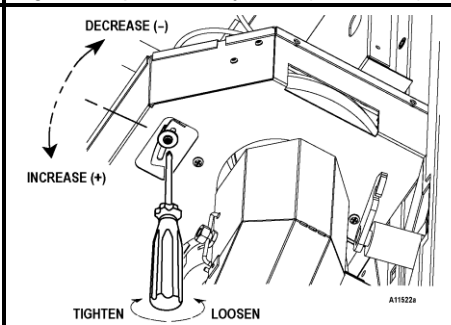

- 3a. Adjust the cup mechanism back and forth so that the cup lip rests on top of the circular cams of the cup dispenser mechanism. See **Figure 8d**.
  - 3b. Push or tap the cup from the bottom end so that it moves up and down freely. If it does not move freely then go back to step 3a.
  - 3c. Pull the cup from the bottom so that it does not easily slip through the circular cams. If it easily slips through then go back to step 3a.
  - 3d. When steps 3a thru 3c are satisfied then tighten the screw. See **Figure 8c**.
4. Place a stack of cups to the left of the cup ring. Go to the internal keypad and press the cup test button. The entire cup stack should advance and fall into the cup ring. Pull on the bottom cup so that it does not easily slip through. If it easily slips through then the mechanism is not tight enough so go back to step 3.

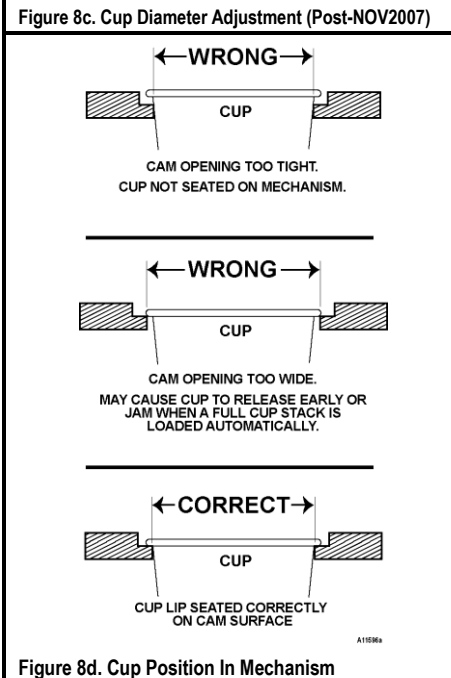

## SET PRICE FOR SINGLE DRINK VOLUME (LARGE)

The following instruction sets the price for the three (3) item types: filled small cup, cup only and a filled large cup. For additional information regarding Set Pricing Modes and Change Prices, please refer to the programming section of this manual.

STEP	DISPLAY
1. On <i>internal</i> keypad, press <b>PROG</b>	PLEASE ENTER ACCESS CODE
2. On <i>external</i> keypad, enter code <b>1111</b>	SET PRICING MODE
3. Press <b>2</b> or <b>8</b> .	CHANGE PRICES
4. Press <b>0</b> .	LARGE PRICES
5. Press <b>2</b> or <b>8</b> to scroll to <b>SET ALL PRICES</b>	SET ALL PRICES
6. Press <b>0</b>	LARGE PRICES
7. Press <b>0</b> to enter a new price	Price=\$0.00
8. Press <b>4</b> (move cursor left) or <b>6</b> (move cursor right), press <b>2</b> (increase value) or press <b>8</b> (decrease value).	
9. Press <b>0</b> to accept the price for <b>ALL LARGE PRICES</b>	
10. Press <b>#</b> (ESCAPE)	LARGE PRICES
11. Press <b>2</b> or <b>8</b> to scroll to other price settings for <b>LARGE PRICE</b> NOTE: This is to set the prices for individual drinks different from the value set in <b>STEP 9</b>	LARGE PRICE
12. Press <b>0</b> to select the drink selection price to change	COFFEE Price= 000.00
13. Press <b>4</b> (move cursor left) or <b>6</b> (move cursor right), press <b>2</b> (increase value) or press <b>8</b> (decrease value).	
14. Press <b>0</b> to accept the price	
15. Repeat steps <b>11</b> to <b>14</b> to set prices for any other drinks	
16. Press <b>#</b> (ESCAPE)	LARGE PRICES
17. Press <b>2</b> or <b>8</b> to scroll to other selection price settings	CUP PRICE
18. Press <b>0</b> to accept <b>CUP PRICE</b> Note: This is <b>DISCOUNTED VALUE</b> for using your own cup	CUP Price=\$0.00
19. Press <b>4</b> (move cursor left) or <b>6</b> (move cursor right), press <b>2</b> (increase value) or press <b>8</b> (decrease value).	
21. Press <b>0</b> to accept the <b>DISCOUNTED VALUE</b>	
22. Press <b>#</b> three times to exit the programming mode.	SELECT DRINK TO SHOW PRICE

## SET PRICES FOR DUAL DRINK VOLUMES (REG & LARGE)

Dual Menu Label set is required to set this option. Order P/N 4214600 Dual Menu Label set.

STEP	DISPLAY
1. On <i>internal</i> keypad, press <b>PROG</b>	PLEASE ENTER ACCESS CODE
2. On <i>external</i> keypad, enter code <b>1111</b>	SET PRICING MODE
3. Press <b>2</b> or <b>8</b> .	CHANGE PRICES
4. Press <b>0</b> .	LARGE PRICES
5. Press <b>2</b> or <b>8</b> to scroll to <b>SET ALL PRICES</b>	SET ALL PRICES
6. Press <b>0</b>	LARGE PRICES
7. Press <b>0</b> to enter a new price	Price= \$000.00
8. Press <b>4</b> (move cursor left) or <b>6</b> (move cursor right), press <b>2</b> (increase value) or press <b>8</b> (decrease value).	
9. Press <b>0</b> to accept the price for <b>ALL LARGE PRICES</b>	
10. Press <b>2</b> or <b>8</b> to scroll to <b>REGULAR PRICES</b>	REGULAR PRICES
11. Press <b>0</b> to enter a new price	Price= \$000.00
12. Press <b>4</b> (move cursor left) or <b>6</b> (move cursor right), press <b>2</b> (increase value) or press <b>8</b> (decrease value).	
13. Press <b>0</b> to accept the price for <b>ALL REGULAR PRICES</b>	
14. Press <b>#</b> (ESCAPE)	LARGE PRICES
15. Press <b>0</b> to select the drink selection price to change NOTE: This is to set the prices for individual drinks different from the value set in <b>STEP 9</b> for <b>LARGE DRINKS</b>	COFFEE Price= \$000.00
16. Press <b>4</b> (move cursor left) or <b>6</b> (move cursor right), press <b>2</b> (increase value) or press <b>8</b> (decrease value).	
17. Press <b>0</b> to accept the price	
18. Press <b>2</b> or <b>8</b> to scroll to <b>REGULAR PRICES</b>	REGULAR PRICES
19. Press <b>0</b> to select the drink selection price to change NOTE: This is to set the prices for individual drinks different from the value set in <b>STEP 13</b> for <b>REGULAR DRINKS</b>	COFFEE Price= \$000.00
20. Press <b>4</b> (move cursor left) or <b>6</b> (move cursor right), press <b>2</b> (increase value) or press <b>8</b> (decrease value).	
21. Press <b>0</b> to accept the price	
22. Press <b>2</b> or <b>8</b> to scroll to other selection price settings	CUP PRICE
23. Press <b>0</b> to accept <b>CUP PRICE</b> Note: This is <b>DISCOUNTED VALUE</b> for using your own cup	CUP Price= \$000.00
24. Press <b>4</b> (move cursor left) or <b>6</b> (move cursor right), press <b>2</b> (increase value) or press <b>8</b> (decrease value).	
21. Press <b>0</b> to accept the <b>DISCOUNTED VALUE</b>	
22. Press <b>#</b> three times to exit the programming mode.	SELECT DRINK TO SHOW PRICE

## FILL CUP COMPARTMENT

The cup mechanism has been factory adjusted for 12 oz. cups.  
Follow the instructions below to adjust the cup diameter size.

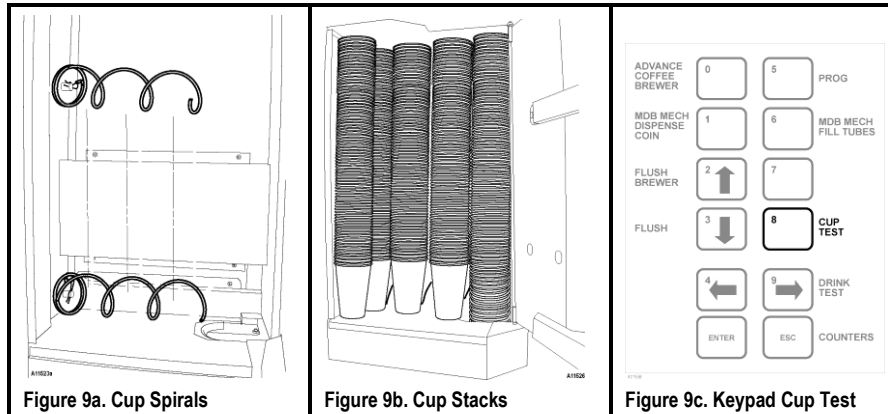

1. Check that the top and bottom spirals are aligned with each other and have room for three (3) stacks of cups. See **Figure 9a**.
2. The cup compartment can have a total of five (5) cup stacks. Load the compartment with cups starting with the first stack in the cup dispenser mechanism followed by three (3) additional cup stacks. See **Figure 9b**. The cup-stack must be aligned with the top and bottom spirals. Add the fifth cup stack directly in from of the fourth cup stack and place it tight against the left side wall of the compartment.
3. Close and latch the cup compartment door.
4. Find the internal keypad on the left side of the door (as viewed from the rear of the door). Press the square marked "8" right next to "CUP TEST". See **Figure 9c**.
  - 4a. The cup should be dispensed via the stainless steel cup chute on and land squarely on the platform of the delivery compartment. See **Figure 9e**.
  - 4b. If the cup gets stuck at the counter-balance wire, then loosen the counterweight and slide it up to lessen the weight against the cup. See **Figure 9d**. Repeat step 4.

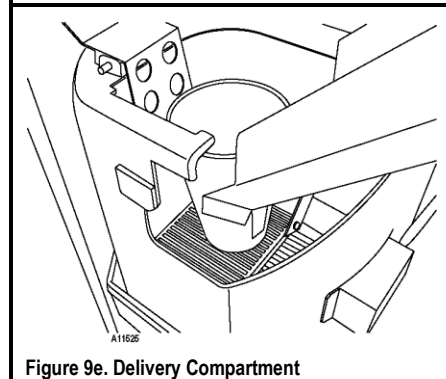
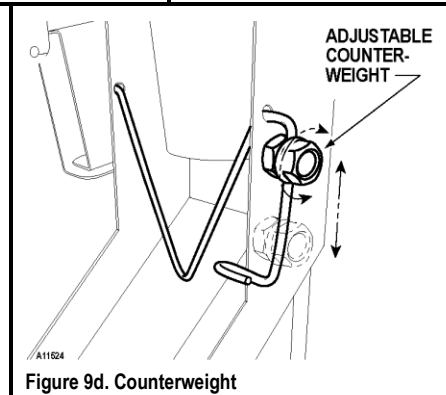

## CUP SIZE ADJUSTMENT

The cup size/volume is factory set at 12 oz.

Follow the example below to change the cup size setting to 8.25 oz.

STEP	DISPLAY
1. On <i>internal</i> keypad, press <b>PROG</b>	PLEASE ENTER ACCESS CODE
2. On <i>external</i> keypad, enter code <b>4444</b>	INGREDIENT TIMES
3. Using 2 or 8 Scroll to <b>CONFIGURE MC</b>	CONFIGURE MC
4. Press 0	GENERAL SETTINGS
5. Using 2 or 8 Scroll to <b>SET CUP SIZE</b>	SET CUP SIZE
6. Press 0	e.g. 12oz
7. Using 2 or 8 Scroll to desired size (7oz, 8.25oz, 9oz, 10oz, 12oz)	8.25oz
8. Press 0 to confirm selection	8.25 oz
9. Press # to exit programming mode	SELECT DRINK TO SHOW PRICE

## FLUSH HEATER TANK, BOWL & BREWER

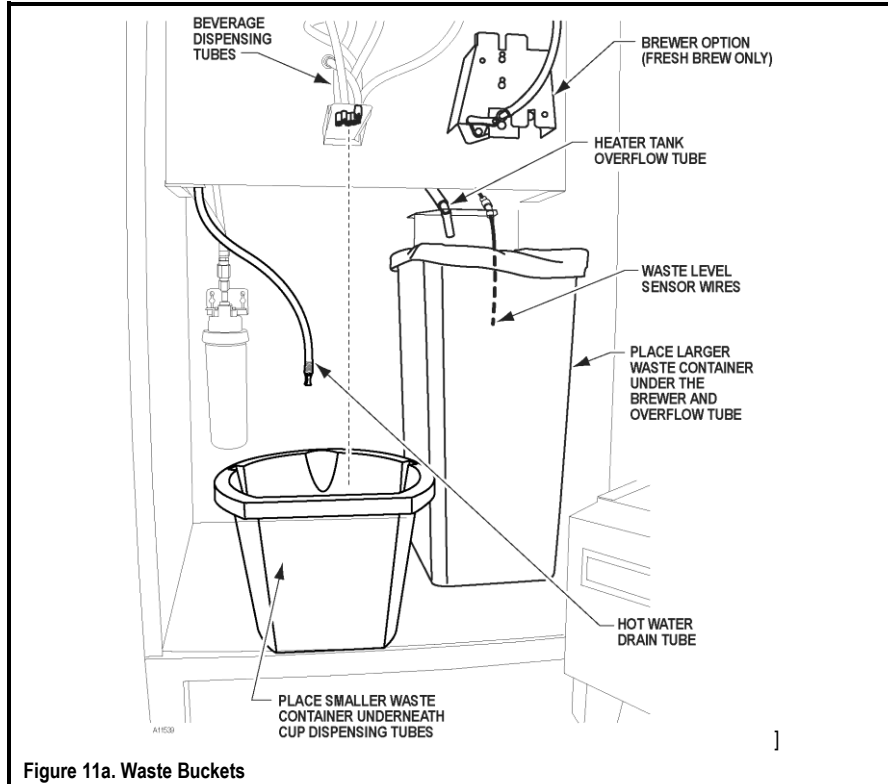

Figure 11a. Waste Buckets

### Install Waste Containers

Place a trash liner (10 Gal) inside the large waste container. Place the waste container under the heater tank overflow tube and the brewer.

Place the small bucket under the cup dispensing tubes. See Figure 11a.

### Flush Whipper Bowls & Brewer

Go to the internal keypad, press the square next to FLUSH to clean the whipper bowls. See Figure 11b.

In a Fresh Brew Machine, after step 3, press the square next to FLUSH BREWERS to clean the brewer and filter. See Figure 11b

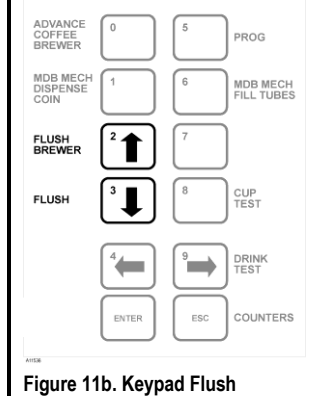

Figure 11b. Keypad Flush

### Flush Hot Water Tank

1. Turn off the Power Switch and shut off the main water valve to the machine. Remove the plug from the hot water tank drain tube and empty the tank contents into the drain bucket. See Figure 11b.
2. Reinstall the plug to the drain tube. Open the main water valve to the machine and turn on the Power Switch.

## DRIP CATCHER

Place a cup on the Drip Catcher Holder to catch any remaining liquid in the base of the cup station from dripping onto the floor when the door is opened during servicing.

1. The Drip Catcher is located on the back of the door underneath the Cup Station.
2. Place a 7 oz or 8.25 oz cup on the Drip Catcher Cup Holder. See **Figure 12a**.
3. **IMPORTANT:**  
Place the Overflow Bucket Sensor inside the drain bucket before closing the door. See **Figure 12b**.

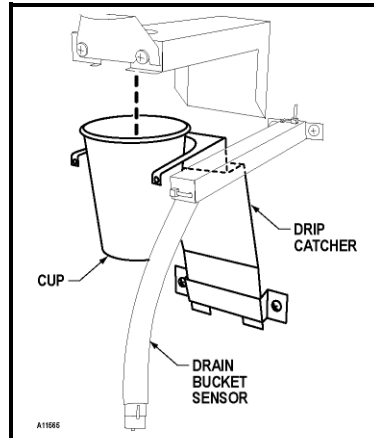

Figure 12a. Drip Catcher

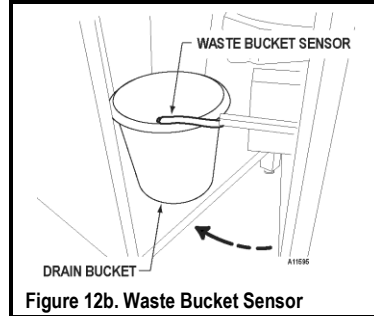

Figure 12b. Waste Bucket Sensor

## **GENERAL DESCRIPTION**

The operational components which form a Hot Beverage Merchandiser are housed in a metal enclosure, access to which is gained by a swivel door secured by a key operated locking mechanism. Turning the key in the lock released a door handle, which allows a three or single point locking mechanism to move to the unlocked state and the door to be opened. With the door open the mains isolation switch for ON/OFF operation of the machine is visible in the top left corner of the machine (above and behind the product canisters).

Equipment inside the cabinet is arranged in two sections: front and rear. On opening the door, the Operator is immediately faced with those items of equipment to which he or she requires access, e.g. Ingredient Canisters, Cup Compartment, Coin Mechanism, Waste Buckets, etc. The remaining items of equipment, e.g. Water Heater, Valves, Electrical and electronics components, etc, to which specifically the Engineer requires access (and from which the Operator must be shielded) are located behind the Ingredient Canisters and Whipper Motor and Dispense Head Assembly panel, at the rear of the cabinet.

## **CABINET FRONT**

The Cup Drop Assembly, Coin Mechanism, Controller Board and Cup Station are fitted to the rear of the door. The Customer's keypad is fitted to the front panel and is connected to the Controller board via a cable assembly.

Ingredient canisters are located on a shelf approximately half way up the cabinet. At the front of the shelf is a duct assembly to which an extractor fan is connected. The fan pulls air from the extract duct, which in turn removes steam/moist air from the mixing systems, which are located on a vertical panel below the canister shelf. The moving dispense head protrudes through and is fastened to this vertical panel and in the case of the fresh brew versions this vertical panel also provides the mounting for the fresh brew units.

On the fresh brew version a large plastic waste bucket is located underneath the Brewer Unit, in addition to the small one placed at the front of the cabinet, beneath the Cup Station (when the door is closed). Water heater overflow pipes, and a water level probe, are directed into the smaller bucket. When the waste liquid in the bucket(s) reaches the level sensor probe, the water supply inlet is shut off and the machine is rendered inoperable.

## **CABINET REAR**

Access to the components and equipment in the rear section of the cabinet is obtained by removing the ingredient canisters and the relevant back panel.

Cold water enters the cabinet through an aperture in the rear panel and connects to a twin chamber inlet valve for the hot water supply. A length of tubing takes the water supply from the inlet valve into the water heater and then to the water heater tank located at the top of the cabinet. Hot water in the correct quantity is then directed from the tank to the appropriate mixing bowl via a solenoid operated dispense valve. A dispense valve is associated with each ingredient. Any overflow from the tank is directed into the waste bucket via an overflow tube. Fitted to this tube is a high temperature cut-out switch, when operated, cuts off the electrical supply to the heater in the tank. The cut-out must then be reset to restore the supply. Another length of tubing facilitates draining of the heater.

A level probe is fitted to the rear of the cabinet door and a similar device is located in the fresh brew waste container. When the door is closed these devices act as contact probes allowing the units control system to monitor the liquid level in the waste containers.

Two printed circuit boards are fitted to the top right hand side of the cabinet rear panel; the DC Remote Input/Output Board (DC RIO) and the Power Supply Unit (PSU). The DC RIO Board provides the high current drives to operate the output devices (valves, motors etc) in response to signals from the Controller Board.

A solid-state relay, located beneath the printed circuit boards, pulses current to the heater in response to signals from the DC RIO Board. The DC RIO board receives signal from the Controller via an I<sup>2</sup>C link. The temperature of the water in the boiler is measured by the Controller Board using an NTC thermistor mounted at the end of a stainless steel probe immersed in the hot water tank.

## **WATER SYSTEM**

The cold water mains supply enters the machine via double-solenoid operated inlet valve at the rear of the cabinet. This valve controls the flow of water to the unit's hot water tank via a water filter.

## **HOT WATER SYSTEM**

Water is supplied via the Hot Inlet valve to the heater tank via a water filter where it is heated to the required temperature by a heating element in the tank. Water temperature is controlled by a combined temperature and level probe assembly in the tank which causes the supply to the heater to be removed when the preset

temperature is reached. The probe assembly also acts as a level sensor, causing the Hot Inlet valve to open when the water in the tank falls below a preset level. The probe (i.e. the input device) is monitored by the Controller Board, and the water heater and Hot Inlet valve (i.e. the output devices) are controlled by the DC RIO Board in response to signals from the Controller Board.

Depending on the type of hot drink selected, hot water from the heater tank is fed via solenoid operated dispense valves to the appropriate mixing bowl or Brewer Unit container. Ingredients and water are mixed in exact quantities in the mixing bowl or Brewer Unit container. Ingredients and water are mixed in exact quantities in the mixing bowl and then directed to the dispense head. Similarly, water and ingredient are brewed in exact amounts in the Brewer Unit and then directed to the dispense head.

A resettable cut-out sensor, mounted on the boiler lid, cuts off the electrical supply to the tank heater circuit if the water in the tank starts to boil. Additionally, if the fluid level in the overflow waste bucket rises above the preset level, it is detected by a level probe and reported to the Controller Board, which responds by closing the inlet valve via the DC RIO Board and rendering the machine inoperable.

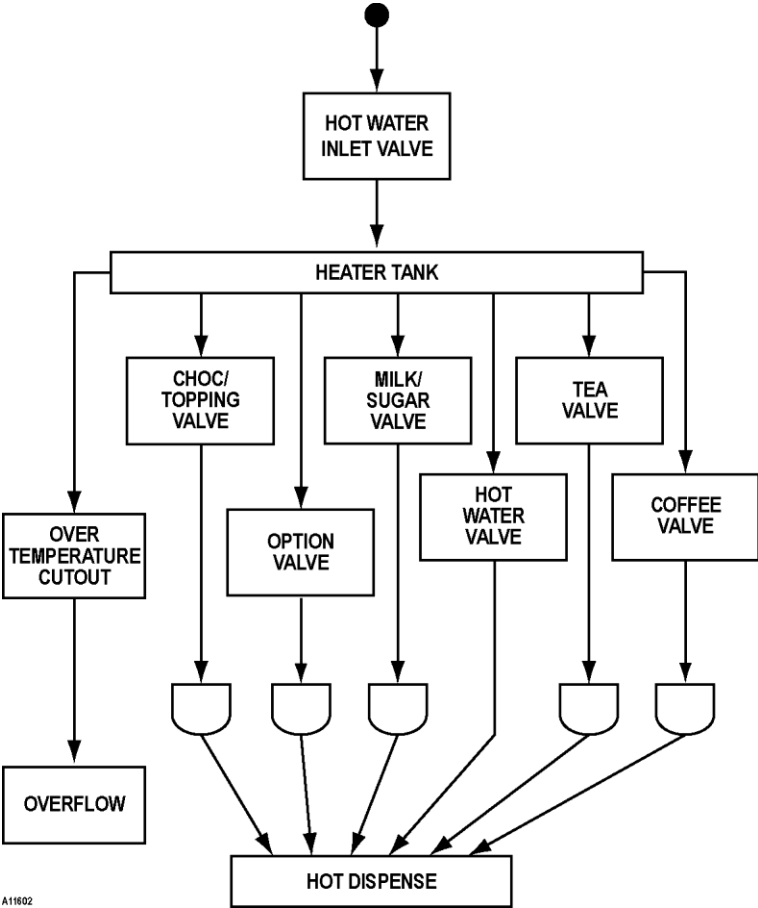

A11802

Fig 1.1A Water System Diagram - Instant

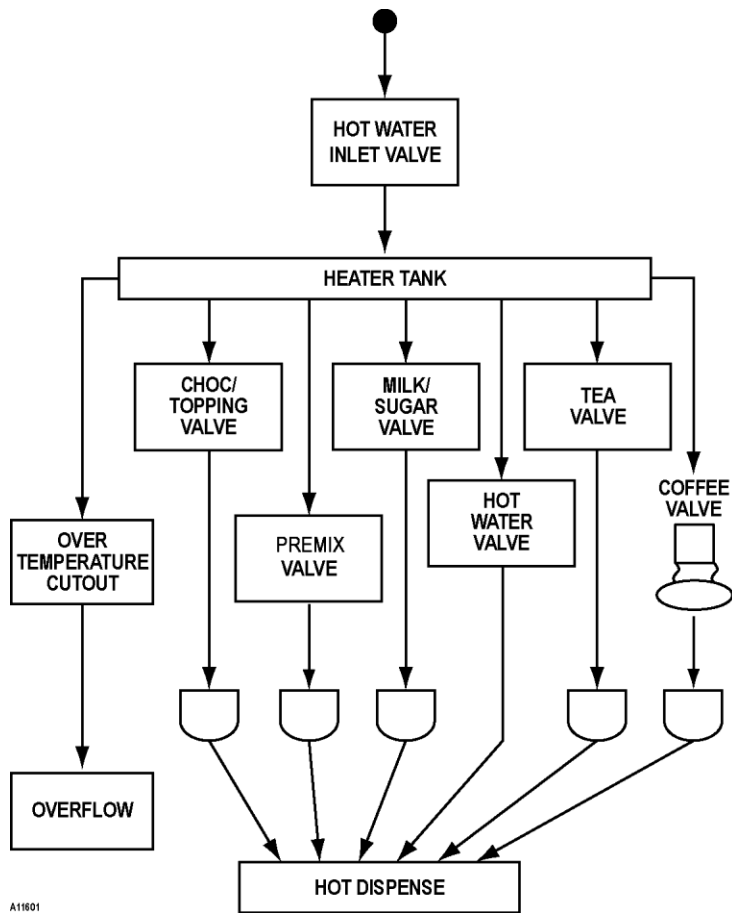
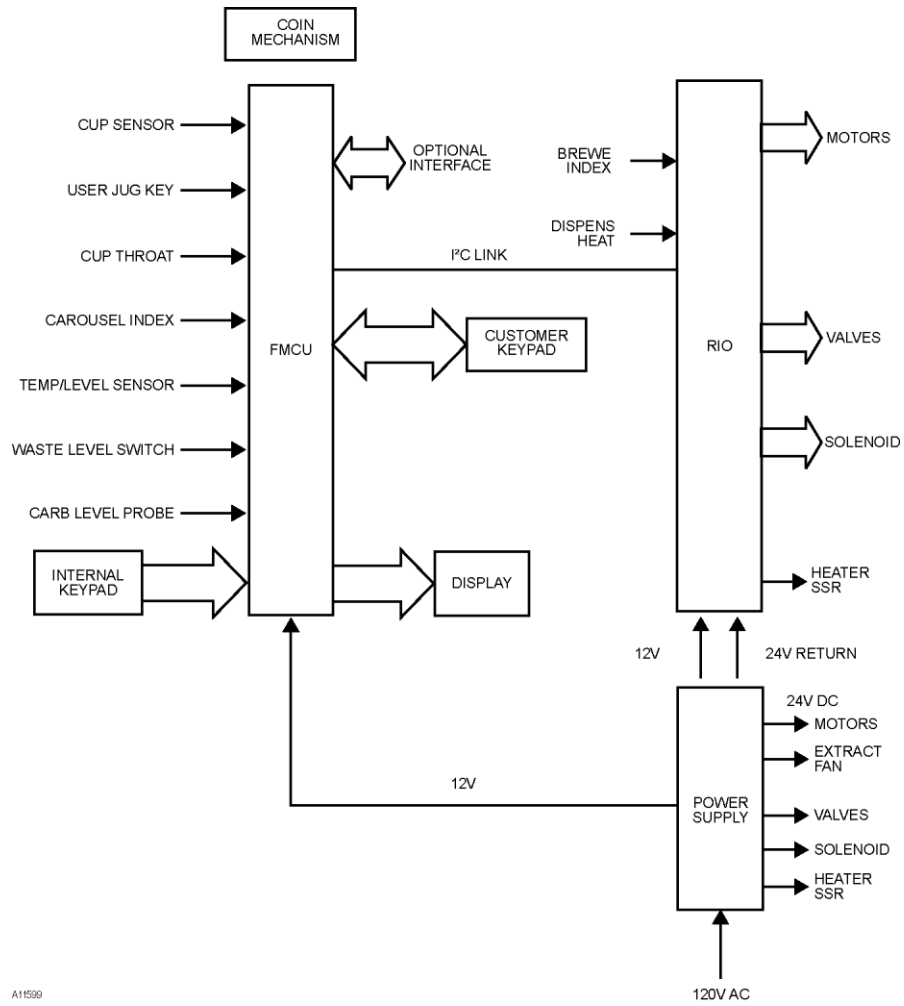

Fig 1.1B Water System Functional Diagram –Fresh Brew



A11599

Fig 1.3 Electrical & Electronic System – Functional Diagram

## INTERNAL KEYPAD FUNCTIONS

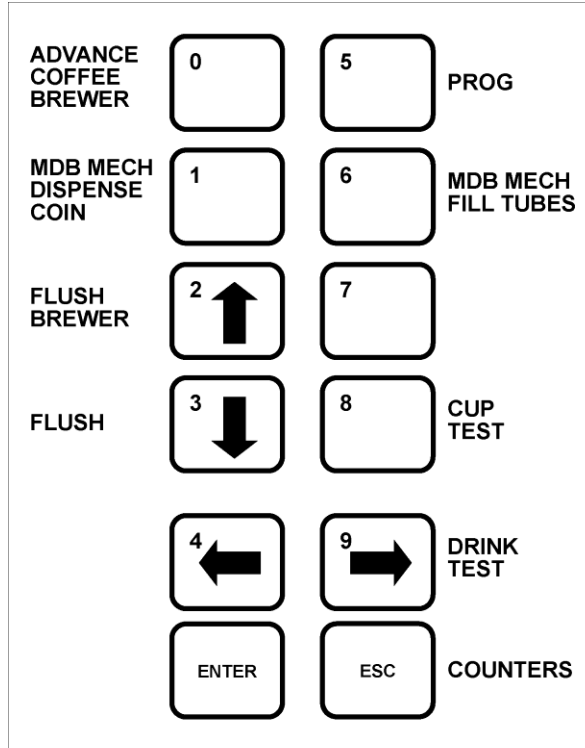

A11538

Fig 2.1

The internal keypad provides the facility to carry out a number of frequently required machine functions without the necessity to enter any of the user programs.

In most cases a single press of the key initiates the function associated with each button. If a further key press is necessary to end the action it will be the ESC (escape) key.

The functions available from the internal keypad are as follows:

- ADVANCE COFFEE BREWER** - If a coffee brewer is fitted, a single depression of this key will cause the brewer unit to index to its next position in the cycle. The purpose of this function is to allow the brewer to be locked prior to a flush cycle so that cleaning agents can be added.
- MDB MECH DISPENSE COIN** - This key provides a method to empty the change tubes of an MDB coin mechanism, which does not itself possess the necessary buttons to do so. On pressing the key the external display will change to:

EMPTY TUBE \$0.05 ↑,↓ ENTER OR ESC
---------------------------------------

The currency value shown will be that of the lower value coin tube in the coin mechanism. The function of the EXTERNAL keys will change as described in section 3 to allow actions to be performed on either the internal or external keypad. Pressing ENTER will cause a coin to be dispensed from the currently selected tube. Pressing the ↑ or ↓ select the next/previous coin tube. Repeated use of the ↑, ↓ & ENTER keys enables all tubes to be emptied. Pressing the ESC (escape) key ends the process.

- BREWER FLUSH** - This key provides the means to initiate a flush cycle of the fresh brew units. A single press of this key will initiate a cleaning cycle for all brewers fitted to the machine simultaneously. In the case of the instant version this function is redundant.

- d) **PROG** - This key activates the code entry sequence required to access the protected levels of the machine control programs. See section 2b.
- e) **MDB MECH FILL TUBES** - If an MDB coin mechanism is fitted this function allows the change tubes to be filled. On pressing the key the external display will change to:

INSERT FLOAT \$0.00
------------------------

As coins are inserted the value displayed will reflect the total value of the money inserted. Pressing ESC (escape) will cause the machine to return to normal operation and zero the credit.

- f) **CUP TEST** - Causes a cup to be dispensed by the cup drop mechanism. The cup spiral will not index unless a selection is made or a cup test performed.
- g) **DRINK TEST** - Allows the next selection to be taken as a free vend.
- h) **COUNTERS** - Pressing the counters key places the machine in manual audit mode. Audit data is accessed via a series of menus. The chart below shows the menu headings in bold text while the key presses required to navigate the menu are shown in *italics*. While in this mode the functions of the EXTERNAL keypad change to allow the menus to be accessed from the same side of the door as the display – see section 3 paragraph 5 for button function in this mode.

## VIEWING COUNTER & EVENT RECORDS

Press the COUNTERS key on the internal keypad and using a combination of the display and the user keypad to navigate (see USER KEYPAD above), the following records can be viewed:

### Heading Menu's List:

- DRINKS COUNTERS: The total number of each primary drink selection
- TOTAL VEND COUNT: The grand total of all drinks vended (includes those vends with use of 'own' cup)
- VENDED CUP COUNT: The number of cups vended
- INGREDIENT COUNTERS: The weight in grams of each primary ingredient
- EVENT LOG: A diagnostic log of events, the description, time and date are recorded
- FINANCIAL AUDIT: A range of sub-menus giving monetary values

### Available Sub-menu's:

- DRINKS COUNTERS Upon pressing ENTER scroll down/up the list of each primary drink selection
- TOTAL VEND COUNT Upon pressing ENTER the grand total is displayed
- VENDED CUP COUNT Upon pressing ENTER the total number of cups dispensed is displayed
- INGREDIENT COUNTERS Upon pressing ENTER scroll down/up the list of each primary ingredient throw weight (in grams): Note: This needs to be set-up in SERVICE MODE to function.
- EVENT LOG Upon pressing ENTER scroll down/up the list recorded events for diagnostic purposes (see table below or more details)
- FINANCIAL AUDIT Upon pressing ENTER the following sub-menus are available:  
PERMANENT COUNTERS – Giving PAID, TEST & FREE Vend values  
TUBE CONTENTS – Each change tube value can be viewed  
RESETTABLE COUNTERS – Giving PAID, TEST & FREE Vend values

**EXAMPLE:** To obtain the 'Total Paid Vend Value'

STEP	DISPLAY
1. On <i>internal</i> keypad, press <b>COUNTERS</b>	<b>DRINK COUNTERS</b>
2. Using 2 or 8 Scroll to <b>FINANCIAL AUDIT</b>	<b>FINANCIAL AUDIT</b>
3. Press <b>0</b>	<b>PERMANENT CTRS</b>
4. Press <b>0</b>	<b>PAID VEND VALUE \$ XX.XX</b>
5. Press # four times to exit programming mode	<b>SELECT DRINK TO SHOW PRICE</b>

## TAKING A TEST VEND

Press the DRINK TEST key on the internal keypad once and then make a drink selection on the external keypad.

If more than one test vend is required, repeat the above procedure.

## DIAGNOSTIC LOG

Displayed Message	Explanation of Condition
KEY STUCK	A key on the user keypad has been closed continuously for >15 seconds
WATER LEAKAGE	The hot inlet valve has had to be switched on > 30 times since the last vend was taken
NO CUPS	Comes into force after 2 unsuccessful attempts to drop a cup
DISPENSE ARM	The arm has not operated the position/limit switches within the designated time allowed
ELECTRONICA	Internal serial communication failure between the control board and the RIO board
IO CONFIG ERR.	Board has not been initialized using the ENG LINK
WASTE TRAY FULL	Either the Liquid or Coffee ground waste bucket is full of water
HEATER INHIBITED	The heater tank has not filled within the 3.5 minute time limit
PLACE OWN CUP	Sold-out of cups
FILLING BOILER	Comes into force 15 seconds after starting to fill the heater tank with water. Indication of a slow rate of fill
C BREWER FAULT	Brewer unit is not cycling correctly – a motor or cycle-switch fault
NEW FILTER REQD	Filter belt warning (if activated) – comes into force after air pressure seen to be present after 7 seconds
FILTER BROKEN	Brewer Fault – comes into force after air pressure has seen to be present after 20 seconds during a vend
DOOR FAULT	Cup door mechanism is not cycling correctly - a motor or cycle-switch fault

### NOTES:

- 1) The event log will only record events that persist for two or more consecutive event log checks. Event log checks take place once every 60s, so in the worst case scenario an event may have to be in force for almost 120s before it is recorded.
- 2) The event log does not handle concurrent events. If two (or more) fault conditions are active, only the first occurrence will be recorded.

## PROGRAMMING

The Hot Beverage Merchandiser has a comprehensive configuration program to allow the behavior and function of the machine to be changed to meet a customer's requirement. There are three levels of access to the configuration functions of the machine. Access to each level is protected by means of a four-digit code. The facilities available at each level are shown below:

1. Operator level access
  - ▶ Access to price related features only.
  - ▶ Factory default Code 1111.
2. Manager level access
  - ▶ Access to Price related features.
  - ▶ Inhibit selections
  - ▶ Limited range modification of recipes.
  - ▶ Change Operator level access code.
  - ▶ Factory default Code 3333.
3. Engineer level access
  - ▶ Full access all features
  - ▶ Factory default code 4444.

## ACCESSING THE USER PROGRAMS

The programs are accessed by pressing key 5 (PROG) on the INTERNAL keypad. The EXTERNAL display will then prompt for input of a four-digit entry code. The code is input using the numbers printed on the keys of the INTERNAL keypad.

- ▶ After pressing the PROG key the display will change to:

PLEASE ENTER  
ACCESS CODE

- ▶ Use the numbered keys on the keypad to enter the correct code. It is not necessary to press ENTER. The code will be checked on entry of the fourth digit. Three attempts are allowed before the PROG key must be pressed again. On entry of a valid code the display will change to the menu heading appropriate to the level of access. While in programming mode the functions of the external keypad change to facilitate navigation of the program using the EXTERNAL keypad.

In the event that the code has been lost or when fitting an un-programmed replacement board it is necessary to complete the circuit between the two pins of the two pin header labeled ENG LINK on the Control board. This bypasses the entry of the four-digit code, giving engineer level access immediately upon processing PROG key. **If the ENG LINK is left in place during power up, the machine will boot straight into the engineers program with full access.**

- ▶ Note Regarding Power Up Problems

The Hot Beverage Merchandiser electronics control system has two major elements. These are the Control board and the DC RIO board. The two boards communicate via a three wire Inter Integrated Circuit bus (I<sup>2</sup>C bus). Some faults affecting the I<sup>2</sup>C bus or Control board configuration can result in persistent system resets. To allow recovery/diagnosis from such situations the control system provides an Access Window to a special 'safe mode' shortly after power is switched on. It is possible to enter engineer's mode during this window.

Some configuration faults related to initialized boards do not allow the system to get even this far through start up, in which case it is necessary to insert the ENG LINK before switching the power on. In this case the machine will boot straight into the engineer's program.

In both cases the I<sup>2</sup>C bus linking the electronics boards is disabled. Without communication between the DC RIO board and the Control board the OUTPUT TEST facility is ineffective and the state of some inputs will be misreported in the INPUT TEST routines. As a reminder to this effect the sound associated with a key press is truncated to a very short pip rather than a beep.

## USER KEYPAD

Having entered a valid code, the keys on the USER keypad are used to navigate and use the functions of the user programs. In programming mode the keys assume the following alternative functions:

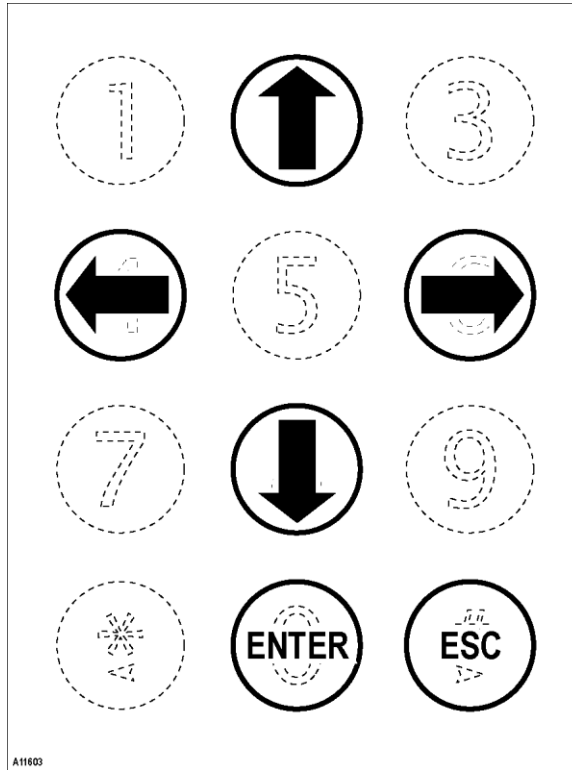

KEY	FUNCTION
↑	Move <b>UP</b> a list of menu options or increment a number.
↓	Move <b>DOWN</b> a list of menu options or decrement a number.
←	Move the cursor <b>LEFT</b> .
→	Move the cursor <b>RIGHT</b> .
ESC	<b>ESCAPE</b> - move to previous menu option or reject values entered.
ENTER	<b>ENTER</b> the menu option displayed or accept the changes made.

## PROGRAM FUNCTIONS

The following table shows the functions available and the access level required to use them within the Hot Beverage Merchandiser configuration program:

FUNCTION	ACCESS LEVEL REQUIRED		
	OPERATOR	MANAGER	ENGINEER
Ingredient Times	-	YES (limited)	YES
Set Date/Time	-	YES	YES
Set Pricing Mode	YES	YES	YES
Change Prices	YES	YES	YES
Inhibit Drink	-	YES	YES
Alter Drink Name	-	YES	YES
Timed Activities	-	-	YES
Temp Settings	-	-	YES
Output Test	-	-	YES
Input Test	-	-	YES
Set Product Consts	-	-	YES
Machine Status	-	-	YES
Set Dry Vend Mode	-	-	YES
Serial Number	-	-	YES
Configure Machine	-	YES (limited)	YES
MDB Config	-	-	YES
EVA-DTS Config	-	-	YES
Product Codes	-	-	YES
Operator's Code	-	YES	YES
Manager's Code	-	-	YES
Engineer's Code	-	-	YES
Free Drink Code		YES	YES
Edit Drink Map	-	-	YES
Card Actions	-	-	YES
Editable Text	-	-	YES
Depressurize CBR	-	YES	YES

## PROGRAMMING SEQUENCE OF OPERATIONS

The method of navigating the menu structure is consistent throughout the program. The ↑ and ↓ keys are used to index through the headings in a particular level or increment/decrement value. Pressing ENTER will select a submenu or confirm a change while ESC (escape) will reject a change or return to the previous menu level. The sequence for accessing a menu option and the accessing a submenu within that option and finally selecting and changing a parameters value, is shown diagrammatically in Fig 3.1.

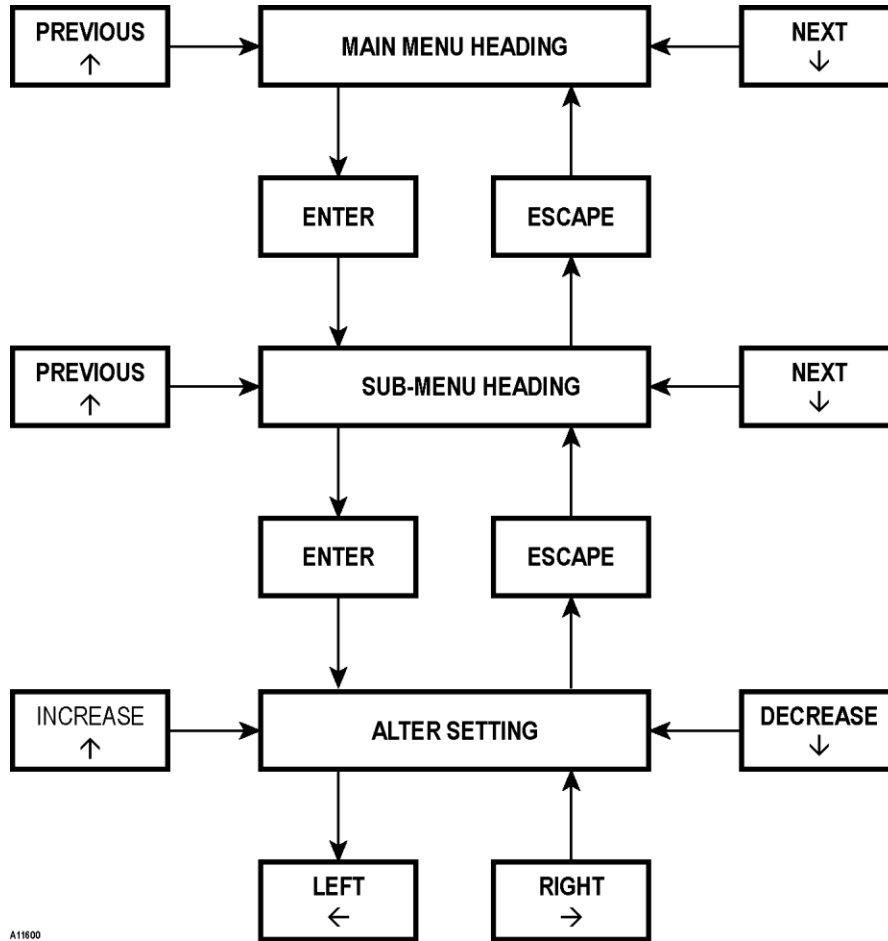

A11600

Fig 3.1 Accessing An Option Setting – Flow Diagram

## MENU OPTIONS

Note: The ADA compatible control software was introduced at version 40

### INGREDIENT TIMES

**Ingredient Times** provides access to a set of submenus, which allow modification of the parameters controlling the recipe and dispensing of individual drinks. The actual content of the sub-menu is dependent on the configuration of the machine. That is for example an Instant Hot version will have different drinks in its **Ingredient Times** sub menu to a **Double Fresh Brew** version fitted with a carbonator. In general the entries of the Ingredient Times menu will consist only of the drinks available on that particular configuration of machine. The Hot Beverage Merchandiser range has a number of pre-defined configurations. For each configuration each selection button is associated with a particular drink. This association is fixed for each configuration. For example if the top left button in a given configuration provides an instant coffee drink then the Coffee entry in the Ingredient sub menu will allow adjustment of a limited number of parameters relating to a coffee selection, it is not possible to reprogram the button to behave as a completely different drink e.g. an **Espresschoc**.

For each selection a user with Manager level access is granted a limited range adjustment on a subset of the parameters. This allows the site-based personnel to perform minor taste profile modifications without the need to call an engineer. The limited range adjustment is implemented as a multiplying scale factor of between 75% and 125%. In **manager's mode** the limited range of adjustment permitted is displayed as a signed value between -25% and +25% and can be changed in 5% increments. For example the limited range strength control for the coffee ingredient of an Espresschoc selection, which has had its coffee ingredient increased by 5% would appear to a manager level user as:

OP: Coffee Mod +5%
-----------------------

When viewed with engineers level access this would appear as:

OP: Coffee Mod 105
-----------------------

In each case the same parameter is being viewed.

The following tables describe the parameters that can be adjusted for each drink, and indicate the parameters visible at the different access levels. The drinks available in each configuration are described in Table 14.b later in this Section.

**BEAN TO CUP RECIPE CHART (S/W REV >36E)**

Parameter Name		Function	Units	12oz		10oz		9oz		8 1/4 oz		7oz	
				Regular	Large	Regular	Large	Regular	Large	Regular	Large	Regular	Large
INFUSION TIME		Delay after coffee and water are added to brew chamber before brewer closes	.1s	70	70	70	70	70	70	70	70	70	70
COFFEE START TIME		Delay before the Coffee ingredient is dispensed	.1s	0	0	0	0	0	0	0	0	0	0
CWTR START TIME 1		Delay before the 2nd shot of Coffee Water is dispensed	.1s	10	10	10	10	10	10	10	10	10	10
CWTR START TIME 2		Delay before the 1st shot of Coffee Water is dispensed	.1s	38	50	31	42	28	38	26	34	22	29
WATER TIME		Coffee brewer dispense valve open duration. The water time is split into 2 equal shots of water	.1s	71	95	59	79	53	71	49	65	41	55
M&S WATER TIME		Milk & Sugar valve opening time	.1s	22	26	18	22	17	20	15	18	13	15
VALVE FACTOR		Balancing factor to account for difference in flow rate between Milk/Sugar valve and brewer valve. If white/sugar drink is smaller than black version increase VAL FACTOR and vice versa. Range 8-14.v	Ratio x 10	10	10	10	10	10	10	10	10	10	10
COFFEE ING TIME		Coffee Grinder Motor	.1s	56	75	47	63	42	56	39	52	33	44
SUGAR TIME		Auger run time for Optional ingredient if selected	.1s	17	22	14	19	13	17	11	15	10	13
SUGAR ADJUSTMENT		Increment applied to sugar auger run time when extra sugar selected	.1s	13	17	11	14	10	13	9	12	8	10
MILK TIME		Auger run time for Optional ingredient if selected	.1s	18	24	15	20	14	18	12	17	10	14
MILK ADJUSTMENT		Increment applied to milk auger run time when extra milk selected	.1s	4	6	3	5	3	5	3	4	2	3
PUMP 1 DURATION		Duration of first air pump operation	.1s	35	41	29	34	25	31	24	28	20	24

PUMP 1 DELAY	Inactive period following first air pump operation	.1s	60	65	50	54	45	49	41	45	35	38
PUMP 2 DURATION	Duration of second air pump operation	.1s	50	59	41	49	38	44	34	40	29	34
PUMP 2 DELAY	Inactive period following second air pump operation	.1s	40	47	33	39	30	35	28	32	23	27
MIXER TIME	Run time for coffee mixer motor referenced to the beginning of the first air pump activity	.1s	20	24	17	20	15	18	14	17	12	14
HOT WATER TIME	Adds hot water directly to cup	.1s	0	0	0	0	0	0	0	0	0	0
BLACK DRAIN TIME	Idle time before head retracts following dispense of selection with no optional components	.1s	20	20	20	20	20	20	20	20	20	20
WHITE DRAIN TIME	Idle time before head retracts following dispense of selection where milk or sugar have been selected	.1s	20	20	22	20	20	20	20	20	20	20
OP: Sugar Mod	Manager level control applied to SUGAR TIME. The actual sugar auger run time will be SUGAR TIME x OP: Sugar Mod/100	%	100	100	100	100	100	100	100	100	100	100

**FRESH BREW RECIPE CHART (S/W REV >29E)**

Parameter Name		Function		12oz		10 oz		9 oz		8 1/4 oz		7 oz	
		Regular	Large	Regular	Large	Regular	Large	Regular	Large	Regular	Large	Regular	Large
INFUSION TIME		.1s	50	50	50	50	50	50	50	50	50	50	50
COFFEE START TIME	Delay after coffee and water are added to brew chamber before brewer closes	.1s	8	8	8	8	8	8	8	8	8	8	8
CWTR START TIME 1	Delay before the Coffee ingredient is dispensed	.1s	1	1	1	1	1	1	1	1	1	1	1
CWTR START TIME 2	Delay before the 2nd shot of Coffee Water is dispensed	.1s	29	39	24	33	22	29	20	27	17	23	23
WATER TIME	Delay before the 1st shot of Coffee Water is dispensed	.1s	71	95	59	79	53	71	49	65	41	55	55
M&S WATER TIME	Coffee brewer dispense valve open duration. The water time is split into 2 equal shots of water	.1s	22	26	18	22	17	20	15	18	13	15	15
VALVE FACTOR	Milk & Sugar valve opening time	Ratio x 10	10	10	10	10	10	10	10	10	10	10	10
COFFEE ING TIME	Balancing factor to account for difference in flow rate between Milk/Sugar valve and brewer valve. If white/sugar drink is smaller than black version increase VAL FACTOR and vice versa. Range 8-14.v	.1s	21	28	19	25	17	23	16	21	14	18	18
SUGAR TIME	Coffee Ingredient Auger Control (30 = 12.5 - 13g)	.1s	17	22	14	19	13	17	11	15	10	13	13
SUGAR ADJUSTMENT	Auger run time for Optional ingredient if selected	.1s	13	17	11	14	10	13	9	12	8	10	10
MILK TIME	Increment applied to sugar auger run time when extra sugar selected	.1s	18	24	15	20	14	18	12	17	10	14	14
MILK ADJUSTMENT	Auger run time for Optional ingredient if selected	.1s	4	6	3	5	3	5	3	4	2	3	3
PUMP 1 DURATION	Increment applied to milk auger run time when extra milk selected	.1s	35	41	29	34	25	31	24	28	20	24	24
	Duration of first air pump operation	.1s											



PUMP 1 DELAY	Inactive period following first air pump operation	.1s	60	65	50	54	45	49	41	45	35	38
PUMP 2 DURATION	Duration of second air pump operation	.1s	50	59	41	49	38	44	34	40	29	34
PUMP 2 DELAY	Inactive period following second air pump operation	.1s	40	47	33	39	30	35	28	32	23	27
MIXER TIME	Run time for coffee mixer motor referenced to the beginning of the first air pump activity	.1s	20	24	17	20	15	18	14	17	12	14
HOT WATER TIME	Adds hot water directly to cup	.1s	0	0	0	0	0	0	0	0	0	0
BLACK DRAIN TIME	Idle time before head retracts following dispense of selection with no optional components	.1s	20	20	20	20	20	20	20	20	20	20
WHITE DRAIN TIME	Idle time before head retracts following dispense of selection where milk or sugar have been selected	.1s	20	20	22	20	20	20	20	20	20	20
OP: Sugar Mod	Manager level control applied to SUGAR TIME. The actual sugar auger run time will be SUGAR TIME x OP: Sugar Mod/100	%	100	100	100	100	100	100	100	100	100	100

<b>WHIPPED COFFEE (FRESH BREW)</b>													
Parameter Name	Function	Units	Regular	Large	Regular	Large	Regular	Large	Regular	Large	Regular	Large	Regular
MIXER TIME	Coffee Whipper	.1s	75	100	62	83	56	75	52	69	44	58	44

<b>WHIPPED DECAF (FRESH BREW)</b>															
Parameter Name	Function	Units	Regular	Large	10 oz	10 oz	10 oz	9 oz	9 oz	9 oz	8 1/4 oz	8 1/4 oz	8 1/4 oz	7 oz	7 oz
MIXER TIME	Coffee Whipper	.1s	75	100	62	83	56	75	52	69	44	58			

FRESH BREW DECAF COFFEE												
Parameter Name	Function	Units	12oz	12 oz	10 oz	10 oz	9 oz	9 oz	8 1/4 oz	8 1/4 oz	7 oz	7 oz
			Regular	Large	Regular	Large	Regular	Large	Regular	Large	Regular	Large
INFUSION TIME	Delay after coffee and water are added to brew chamber before brewer closes	.1s	50	50	50	50	50	50	50	50	50	50
COFFEE START TIME	Delay before the Coffee ingredient is dispensed	.1s	8	8	8	8	8	8	8	8	8	8
CWTR START TIME 1	Delay before the 2nd shot of Coffee Water is dispensed	.1s	1	1	1	1	1	1	1	1	1	1
CWTR START TIME 2	Delay before the 1st shot of Coffee Water is dispensed	.1s	29	39	24	33	22	29	20	27	17	23
WATER TIME	Coffee brewer dispense valve open duration. The water time is split into 2 equal shots of water	%	71	95	59	79	53	71	49	65	41	55
M&S WATER TIME	Milk & Sugar valve opening time	0	22	26	18	22	17	20	15	18	13	15
VALVE FACTOR	Balancing factor to account for difference in flow rate between Milk/Sugar valve and brewer valve. If white/sugar drink is smaller than black version increase VF and vice versa. Range 8-14.	Ratio x 10	10	10	10	10	10	10	10	10	10	10
COFFEE ING TIME	Coffee Ingredient Auger Control (30 = 12.5 - 13g)	.1s	21	28	19	25	17	23	16	21	14	18
SUGAR TIME	Auger run time for Optional ingredient if selected	.1s	17	22	14	19	13	17	11	15	10	13
SUGAR ADJUSTMENT	Increment applied to sugar auger run time when extra sugar selected	.01s	13	17	11	14	10	13	9	12	8	10
MILK TIME	Auger run time for Optional ingredient if selected	.01s	18	24	15	20	14	18	12	17	10	14
MILK ADJUSTMENT	Increment applied to milk auger run time when extra milk selected	.1s	4	6	3	5	3	5	3	4	2	3
PUMP 1 DURATION	Duration of first air pump operation	.1s	35	41	29	34	26	31	24	28	20	24

PUMP 2 DURATION	Duration of second air pump operation	.1s	50	59	42	49	38	44	34	41	29	34
PUMP 2 DELAY	Inactive period following second air pump operation	.1s	40	47	33	39	30	35	28	32	23	27
MIXER TIME	Run time for coffee mixer motor referenced to the beginning of the first air pump activity	.1s	20	24	17	20	15	18	14	17	12	14
HOT WATER TIME	Adds hot water directly to cup	.1s	0	0	0	0	0	0	0	0	0	0
BLACK DRAIN TIME	Idle time before head retracts following dispense of selection with no optional components	.1s	20	20	20	20	20	20	20	20	20	20
WHITE DRAIN TIME	Idle time before head retracts following dispense of selection where milk or sugar have been selected	.1s	20	20	22	20	20	20	20	20	20	20
OP: Sugar Mod	Manager level control applied to SUGAR TIME. The actual sugar auger run time will be SUGAR TIME x OP: Sugar Mod/100	%	100	100	100	100	100	100	100	100	100	100
OP: Milk Mod	Manager level control applied to MILK TIME. The actual milk auger run time will be MILK TIME x OP: Milk Mod/100	%	100	100	100	100	100	100	100	100	100	100
OP: Coffee Mod	Manager level control applied to COFFEE TIME. The actual sugar auger run time will be COFFEE TIME x OP: Coffee Mod/100	%	100	100	100	100	100	100	100	100	100	100
OP: Water Mod	Manager level control applied to WATER TIME. The actual milk auger run time will be WATER TIME x OP: Water Mod/100	%	100	100	100	100	100	100	100	100	100	100

ESPRESSO (FRESH BREW COFFEE)												
Parameter Name	Function	Units	12oz	12 oz	10 oz	10 oz	9 oz	9 oz	8 1/4 oz	8 1/4 oz	7 oz	7 oz
			Regular	Large	Regular	Large	Regular	Large	Regular	Large	Regular	Large
INFUSION TIME	Delay after coffee & water are added to brew chamber before brewer closes	.1s	50	50	50	50	50	50	50	50	50	50
COFFEE START TIME	Delay before the Coffee ingredient is dispensed	.1s	0	0	0	0	0	0	0	0	0	0
CWTR START TIME 1	Delay before the 2nd shot of Coffee Water is dispensed	.1s	4	4	4	4	4	4	4	4	4	4
CWTR START TIME 2	Delay before the 1st shot of Coffee Water is dispensed	.1s	15	20	13	17	11	15	10	14	9	12
WATER TIME	Coffee brewer dispense valve open duration. The water time is split into 2 equal shots of water	.1s	38	50	31	42	28	38	26	34	22	29
M&S WATER TIME	Milk & Sugar valve opening time	.1s	18	24	15	20	14	18	12	17	11	14
SUGAR TIME	Auger run time for Optional ingredient if selected	.1s	17	22	14	19	13	17	11	15	10	13
SUGAR ADJUSTMENT	Increment applied to milk auger run time when extra milk selected	.1s	0	0	0	0	0	0	0	0	0	0
MILK TIME	Auger run time for Optional ingredient if selected	.1s	15	20	12	17	11	15	10	14	9	12
MILK ADJUSTMENT	Increment applied to milk auger run time when extra milk is selected	.1s	3	5	2	4	2	4	2	3	2	3
COFFEE ING TIME	Coffee Ingredient Auger Control (30 = 12.5 - 13g)	.1s	17	22	14	18	12	17	11	15	10	13
VALVE FACTOR	Balancing factor to account for difference in flow rate between Milk/Sugar valve and brewer valve. If white/sugar drink is smaller than black version increase VALVE FACTOR and vice versa. Range 8-14.	ratio	12	12	12	12	12	12	12	12	12	12
PUMP 1 DURATION	Duration of first air pump operation	.1s	20	24	17	20	15	18	14	17	12	14

PUMP 1 DELAY	Inactive period following first air pump operation	.1s	40	47	33	39	30	35	28	32	23	27
PUMP 2 DURATION	Duration of second air pump operation	.1s	15	18	13	15	11	14	10	12	9	11
PUMP 2 DELAY	Inactive period following second air pump operation	.1s	30	35	25	29	23	26	21	24	18	20
MIXER TIME	Run time for coffee mixer motor referenced to the beginning of the first air pump activity	.1s	60	71	50	59	45	53	51	59	35	41
HOT WATER TIME	Run time for hot water directly into cup	.1s	0	0	0	0	0	0	0	0	0	0
BLACK DRAIN TIME	Idle time before head retracts following dispense of selection with no optional components.	.1s	20	20	20	20	20	20	20	20	20	20
WHITE DRAIN TIME	Idle time before head retracts following dispense of selection where milk or sugar have been selected	.1s	20	20	22	20	20	20	20	20	20	20
OP: Sugar Mod	Manager level control applied to SUGAR TIME. The actual sugar auger run time will be SUGAR TIME x OP: Sugar Mod/100	%	100	100	100	100	100	100	100	100	100	100
OP: Milk Mod	Manager level control applied to MILK TIME. The actual milk auger run time will be MILK TIME x OP: Milk Mod/100	%	100	100	100	100	100	100	100	100	100	100
OP: Coffee Mod	Manager level control applied to COFFEE TIME. The actual sugar auger run time will be COFFEE TIME x OP: Coffee Mod/100	%	100	100	100	100	100	100	100	100	100	100

<b>CAFÉ MOCHA (FRESH BREW COFFEE)</b>												
Parameter Name	Function	Units	12oz	12 oz	10 oz	10 oz	9 oz	9 oz	8 1/4 oz	8 1/4 oz	7 oz	7 oz
			Regular	Large	Regular	Large	Regular	Large	Regular	Large	Regular	Large
COFFEE TIME	Coffee Ingredient Auger Control	1.0s	17	22	14	18	12	17	11	15	10	13
COFFEE START TIME	Delay before the Coffee ingredient is dispensed	.1s	0	0	0	0	0	0	0	0	0	0
CWTR START TIME 1	Delay before the 2nd shot of Coffee Water is dispensed	.1s	0	0	0	0	0	0	0	0	0	0
CWTR START TIME 2	Delay before the 1st shot of Coffee Water is dispensed	.1s	23	30	19	25	17	23	15	21	13	18
COFFEE WATER	Coffee brewer dispense valve open duration. The water time is split into 2 equal shots of water	0.1s	38	50	31	42	28	38	26	34	22	29
COFFEE MIXER TIME	Run time for coffee mixer motor referenced to the beginning of the first air pump activity	0.1s	70	82	58	68	53	62	48	56	41	48
TOPPING TIME	Auger run time for ingredient	0.1s	0	0	0	0	0	0	0	0	0	0
CHOCOLATE TIME	Auger run time for ingredient	0.1s	23	35	19	29	17	26	16	24	13	20
CHOC WATER TIME	Choc/Topping dispense valve open duration	0.1s	38	50	31	42	28	38	26	34	22	29
CHOC MIXER TIME	Run time for choc/topping mixer motor	0.1s	45	60	38	50	34	45	31	41	26	35
BREWER START	Brewer cycle start time	0.1s	80	94	66	78	60	71	55	65	47	55
PUMP 1 DURATION	Duration of first air pump operation	0.1s	35	41	29	34	26	31	24	28	20	24
PUMP 1 DELAY	Inactive period following first air pump operation	0.1s	50	59	42	49	38	44	34	41	29	34
PUMP 2 DURATION	Duration of second air pump operation	0.1s	40	47	33	39	30	35	28	32	23	27
PUMP 2 DELAY	Inactive period following second air pump operation	0.1s	40	47	33	39	30	35	28	32	23	27
SUGAR TIME	Auger run time for Optional ingredient if selected	0.1s	17	22	14	19	13	17	11	15	10	13
SUGAR WTR TIME	Sugar valve opening time	0.1s	30	35	25	29	23	26	21	24	18	20
SUGAR MIXER TIME	0	0.1s	40	47	33	39	30	35	28	32	23	27



<b>CAPPUCCINO (FRESH BREW COFFEE)</b>												
Parameter Name	Function	Units	12oz	12 oz	10 oz	10 oz	9 oz	9 oz	8 1/4 oz	8 1/4 oz	7 oz	7 oz
			Regular	Large	Regular	Large	Regular	Large	Regular	Large	Regular	Large
MILK START	Start time topping & sugar components. Referenced to t=0	.1s	10	10	10	10	10	10	10	10	10	10
INFUSION TIME	Delay after coffee & water are added to brew chamber before brewer closes	.1s	50	50	50	50	50	50	50	50	50	50
COFFEE START TIME	Delay before the Coffee ingredient is dispensed	.1s	0	0	0	0	0	0	0	0	0	0
CWTR START TIME 1	Delay before the 2nd shot of Coffee Water is dispensed	.1s	0	0	0	0	0	0	0	0	0	0
CWTR START TIME 2	Delay before the 1st shot of Coffee Water is dispensed	.1s	23	30	19	25	17	23	15	21	13	18
WATER TIME	Coffee brewer dispense valve open duration. The water time is split into 2 equal shots of water	.1s	38	50	31	42	28	38	26	34	22	29
MILK/SUGAR WATER TIME	Topping dispense valve open duration	.1s	30	40	25	33	23	30	21	28	18	23
COFFEE ING TIME	Coffee Ingredient Auger Control	.1s	21	28	17	23	16	21	14	19	12	16
COFFEE MIXER TIME	Run time for coffee mixer motor referenced to the beginning of the first air pump activity	.1s	30	40	25	33	23	30	21	28	18	23
MILK MIXER TIME	Run time for milk mixer motor	.1s	60	65	50	55	45	50	40	45	40	45
SUGAR TIME	Auger run time for Optional ingredient if selected	.1s	17	22	14	19	13	17	11	15	10	13
SUGAR ADJUSTMENT	Increment applied to sugar auger run time when extra sugar selected	.1s	13	17	11	14	10	13	9	12	8	10
MILK TIME	Auger run time for Topping Ingredient	.1s	40	54	33	45	30	41	28	37	23	31
PUMP 1 DURATION	Duration of first air pump operation	.1s	35	41	29	34	26	31	24	28	20	24
PUMP 1 DELAY	Inactive period following first air pump operation	.1s	50	59	42	49	38	44	43	41	29	34
PUMP 2 DURATION	Duration of second air pump operation	.1s	40	47	33	39	30	35	28	32	23	27
PUMP 2 DELAY	Inactive period following second air pump operation	.1s	40	47	33	39	30	35	28	32	23	27

HOT WATER TIME	Run time for hot water directly into cup	.1s	0	0	0	0	0	0	0	0	0	0	0	0	0	0	0	0	0
OP: Sugar Mod	Manager level control applied to SUGAR TIME. The actual sugar auger run time will be SUGAR TIME x OP: Sugar Mod/100	%	100	100	100	100	100	100	100	100	100	100	100	100	100	100	100	100	100
OP: Milk Mod	Manager level control applied to TOPPING TIME. The actual topping auger time will be TOPPING TIME x OP: Milk Mod/100	%	100	100	22	100	100	100	100	100	100	100	100	100	100	100	100	100	100
OP: Coffee Mod		%	100	100	100	100	100	100	100	100	100	100	100	100	100	100	100	100	100
OP: Water Mod	Manager level control applied to water times. The actual dispense valve open times will be <TIME> x OP: Water Mod/100	%	100	100	100	100	100	100	100	100	100	100	100	100	100	100	100	100	100

CAFÉ LATTE (FRESH BREW COFFEE)												
Parameter Name	Function	Units	12oz	12 oz	10 oz	10 oz	9 oz	9 oz	8 1/4 oz	8 1/4 oz	7 oz	7 oz
			Regular	Large	Regular	Large	Regular	Large	Regular	Large	Regular	Large
COFFEE ING TIME	Coffee Ingredient Auger Control	.1s	21	27	17	23	15	21	14	19	12	16
INFUSION TIME	Delay after coffee & water are added to brew chamber before brewer closes	.1s	50	50	50	50	50	50	50	50	50	50
COFFEE START TIME	Delay before the Coffee ingredient is dispensed	.1s	0	0	0	0	0	0	0	0	0	0
CWTR START TIME 1	Delay before the 2nd shot of Coffee Water is dispensed	.1s	0	0	0	0	0	0	0	0	0	0
CWTR START TIME 2	Delay before the 1st shot of Coffee Water is dispensed	.1s	23	30	19	25	17	23	15	21	13	18
WATER TIME	Coffee brewer dispense valve open duration. The water time is split into 2 equal shots of water	.1s	38	50	31	42	28	38	26	34	22	29
PUMP 1 DURATION	Duration of first air pump operation	.1s	31	41	26	34	23	31	21	28	18	24
PUMP 1 DELAY	Inactive period following first air pump operation	.1s	44	58	36	49	33	44	30	40	26	34
PUMP 2 DURATION	Duration of second air pump operation	.1s	35	46	29	39	26	35	24	32	20	27
PUMP 2 DELAY	Inactive period following second air pump operation	.1s	35	46	29	39	26	35	24	32	20	27
HOT WATER TIME	Run time for hot water directly into cup	.1s	0	0	0	0	0	0	0	0	0	0
COFFEE MIXER TIME	Run time for coffee mixer motor referenced to the beginning of the first air pump activity	.1s	45	60	38	50	34	45	31	41	26	35
MILK START	Start time topping & sugar components. Referenced to t=0	.1s	103	137	86	114	77	103	71	94	60	80
MILK TIME	Auger run time for Topping Ingredient	.1s	40	54	33	45	30	41	28	37	23	31
MILK/SUGAR WATER TIME	Topping dispense valve open duration	.1s	30	40	25	33	23	30	21	28	18	23
SUGAR TIME	Auger run time for Optional ingredient if selected	.1s	17	22	14	19	13	17	12	15	10	13
SUGAR ADJUSTMENT	Increment applied to sugar auger run time when extra sugar selected	.1s	13	17	11	14	10	13	9	12	8	10

MILK MIXER TIME	Run time for milk mixer motor	.1s	45	60	38	50	34	45	31	41	26	35
OP: Sugar Mod	Manager level control applied to SUGAR TIME. The actual sugar auger run time will be SUGAR TIME x OP: Sugar Mod/100	%	100	100	100	100	100	100	100	100	100	100
OP: Milk Mod	Manager level control applied to TOPPING TIME. The actual topping auger time will be TOPPING TIME x OP: Milk Mod/100	%	100	100	22	100	100	100	100	100	100	100
OP: Coffee Mod	Manager level control applied to COFFEE ING TIME. The actual coffee auger run time will be COFFEE ING TIME x OP: Coffee Mod/100	%	100	100	100	100	100	100	100	100	100	100
OP: Water Mod	Manager level control applied to water times. The actual dispense valve open times will be <TIME> x OP: Water Mod/100	%	100	100	100	100	100	100	100	100	100	100

<b>CHOCOLATE</b>												
Parameter Name	Function	Units	12oz	12 oz	10 oz	10 oz	9 oz	9 oz	8 1/4 oz	8 1/4 oz	7 oz	7 oz
			Regular	Large	Regular	Large	Regular	Large	Regular	Large	Regular	Large
CHOCOLATE TIME	Auger run time for Chocolate ingredient	.1s	67	90	56	75	50	68	46	62	39	52
WATER TIME	Chocolate dispense valve open duration	.1s	105	140	87	117	79	105	72	87	62	82
MIXER START	Chocolate mixer start time	.1s	10	12	8	10	8	9	7	8	6	7
MIXER TIME	Chocolate mixer motor run time	.1s	125	147	104	123	94	110	80	102	73	86
OP: Chocolate Mod	Manager level control applied to CHOCOLATE TIME. The actual chocolate run time will be CHOCOLATE TIME x OP: Chocolate Mod/100	%	100	100	100	100	100	100	100	100	100	100
OP: Water Mod	Manager level control applied to WATER TIME. The actual dispense valve open time will be WATER TIME x OP: Water Mod/100	%	100	100	100	100	100	100	100	100	100	100

FRENCH VANILLA CAPP.												
Parameter Name	Function	Units	12oz	12 oz	10 oz	10 oz	9 oz	9 oz	8 1/4 oz	8 1/4 oz	7 oz	7 oz
			Regular	Large	Regular	Large	Regular	Large	Regular	Large	Regular	Large
PREMIX TIME	Auger run time for ingredient	.1s	60	80	50	67	45	60	41	55	35	47
WATER TIME	Water dispense valve open duration	.1s	100	130	84	109	76	98	68	90	59	76
SUGAR TIME	Auger run time for Optional ingredient if selected	.1s	17	22	14	19	13	17	11	15	10	13
SUGAR ADJUSTMENT	Increment applied to sugar auger run time when extra sugar selected	.1s	0	0	0	0	0	0	0	0	0	0
SUGAR WATER	Increment applied to milk auger run time when extra milk selected	.1s	25	29	21	24	19	22	17	20	15	17
SUGAR START	Referenced to the start of water time above	.1s	40	47	33	39	30	35	28	32	23	27
MIXER TIME	0	.1s	110	140	94	119	86	108	78	100	69	86
MIXER START	0	.1s	10	10	10	10	10	10	10	10	10	10
OP: Sugar Mod	Manager level control applied to SUGAR TIME. The actual sugar auger run time will be SUGAR TIME x OP: Sugar Mod/100	%	100	100	100	100	100	100	100	100	100	100
OP: Milk Mod	Manager level control applied to MILK TIME. The actual milk auger run time will be MILK TIME x OP: Milk Mod/100	%	100	100	100	100	100	100	100	100	100	100
OP: Tea Mod	Manager level control applied to TEA TIME. The actual tea auger run time will be TEA TIME x OP: Tea Mod/100	%	100	100	100	100	100	100	100	100	100	100
OP: Water Mod	Manager level control applied to WATER TIME. The actual dispense valve open time will be WATER TIME x OP: Water Mod/100.	%	100	100	100	100	100	100	100	100	100	100

<b>ENGLISH TOFFEE</b>												
Parameter Name	Function	Units	12oz	12 oz	10 oz	10 oz	9 oz	9 oz	8 1/4 oz	8 1/4 oz	7 oz	7 oz
			Regular	Large	Regular	Large	Regular	Large	Regular	Large	Regular	Large
Ingrd. TIME	Auger run time for ingredient	.1s	60	80	50	67	45	60	41	55	35	47
WATER TIME	Water dispense valve open duration	.1s	100	130	84	109	76	98	68	90	59	76
MIXER START	Mixer start time	.1s	10	10	10	10	10	10	10	10	10	10
MIXER TIME	Mixer motor run time	.1s	110	140	94	119	86	108	78	100	69	86
OP: Chocolate Mod	Manager level control applied to CHOCOLATE TIME. The actual chocolate run time will be CHOCOLATE TIME x OP: Chocolate Mod/100	%	100	100	100	100	100	100	100	100	100	100
OP: Water Mod	Manager level control applied to WATER TIME. The actual dispense valve open time will be WATER TIME x OP: Water Mod/100	%	100	100	100	100	100	100	100	100	100	100

TEA												
Parameter Name	Function	Units	12oz	12 oz	10 oz	10 oz	9 oz	9 oz	8 1/4 oz	8 1/4 oz	7 oz	7 oz
			Regular	Large	Regular	Large	Regular	Large	Regular	Large	Regular	Large
TEA TIME	Auger run time for tea ingredient	.1s	12	15	10	12	9	11	8	10	7	9
TEA ADJUSTMENT	Increment applied to Tea auger run time when strong selected	.1s	n/a	n/a	n/a	n/a	n/a	n/a	n/a	n/a	n/a	n/a
WATER TIME	Tea water dispense valve open duration	.1s	87	116	79	97	65	87	60	80	51	68
WATER SPLIT	Fraction of total water time, above, to be allocated to the milk sugar valve if mil or sugar is selected	%	50	50	50	50	50	50	50	50	50	50
SUGAR TIME	Auger run time for Optional ingredient if selected	.1s	17	22	14	19	13	17	11	15	10	13
SUGAR ADJUSTMENT	Increment applied to sugar auger run time when extra sugar selected	.1s	13	17	11	14	10	13	9	12	8	10
MILK TIME	Auger run time for Optional ingredient if selected	.1s	20	26	17	20	15	19	14	17	12	15
MILK ADJUSTMENT	Increment applied to milk auger run time when extra milk selected	.1s	5	5	5	5	4	4	4	4	3	3
VALVE FACTOR	Compensating variable to account for differing flow rates between milk/sugar and tea valves. If white/sugar drink is bigger than black version decrease, if bigger increase.	Ratio x 10	10	10	10	10	10	10	10	10	10	10
OP: Sugar Mod	Manager level control applied to SUGAR TIME. The actual sugar auger run time will be SUGAR TIME x OP: Sugar Mod/100	%	100	100	100	100	100	100	100	100	100	100
OP: Milk Mod	Manager level control applied to MILK TIME. The actual milk auger run time will be MILK TIME x OP: Milk Mod/100	%	100	100	100	100	100	100	100	100	100	100
OP: Tea Mod	Manager level control applied to TEA TIME. The actual tea auger run time will be TEA TIME x OP: Tea Mod/100	%	100	100	100	100	100	100	100	100	100	100
OP: Water Mod	Manager level control applied to WATER TIME. The actual dispense valve open time will be WATER TIME x OP: Water Mod/100.	%	100	100	100	100	100	100	100	100	100	100

CHAI TEA / LATTE												
Parameter Name	Function	Units	12oz	12 oz	10 oz	10 oz	9 oz	9 oz	8 1/4 oz	8 1/4 oz	7 oz	7 oz
			Regular	Large	Regular	Large	Regular	Large	Regular	Large	Regular	Large
TEA TIME	Auger run time for tea ingredient	.1s	38	50	31	42	28	38	26	34	22	29
WATER TIME	Tea water dispense valve open duration	.1s	87	116	79	97	65	87	60	80	51	68
MIXER START	Chocolate mixer start time	.1s	10	10	10	10	10	10	10	10	10	10
MIXER TIME	Chocolate mixer motor run time	.1s	90	120	80	100	70	90	60	80	50	70
OP: Tea Mod	Manager level control applied to TEA TIME. The actual tea auger run time will be TEA TIME x OP: Tea Mod/100	%	100	100	100	100	100	100	100	100	100	100
OP: Water Mod	Manager level control applied to WATER TIME. Dispense valve open time will be WATER TIME x OP: Water Mod/100.	%	100	100	100	100	100	100	100	100	100	100

**IMPORTANT NOTE:**

If the tea selection is to be substituted with a Chai Tea Latte or a similar product, the mixing station will need to be 'whipped', in which case the following parts & modification will be required:-

**Parts required:**

- a) 1217354.001 Whipper Motor Assembly - Beige
- b) 4214445 Impellor disc
- c) 4214449 Shaft Seal - Red

**Electrical wiring modification:**

There is no electrical provision to drive a whipper motor for the 'Tea' mixing station. It will therefore be necessary to run a pair of wires from the 'E' hot water delivery solenoid valve (5th valve from left) to operate the whipper motor; such that the Red/White wire connects to the '+' terminal and the Gray/Orange wire to the '-' terminal of the whipper motor.

## **SET DATE AND TIME**

Entering SET DATE & TIME provides access to a sub-menu consisting of SET DATE and SET TIME.

Set Date

The SET DATE option allows the programmer to change the displayed date.

Set Time

The SET TIME option allows the programmer to change the displayed time.

The battery fitted to the FMCU control board has an open circuiting link to prevent discharge during extended periods of storage. When commissioning a new board the links labeled CLOCK BAT on the control board must be fitted otherwise the board will not maintain the time when power is removed.

The FMCU control board contains a lithium battery. Care should be taken to dispose of this in an appropriate manner should a board be scrapped. The board should not be disposed of by burning.

## **SET PRICING MODE**

Entering SET MODB PRICING allows the programmer to select one of the following Pricing modes:

- ▶ Prices Apply
- ▶ All Drinks Free

The selected mode becomes the default setting to which the machine will return after timed activities.

## **CHANGE PRICES**

Entering CHANGE PRICES provides access to the following sub-menu:

- ▶ LARGE PRICES
- ▶ REGULAR PRICES
- ▶ SET ALL PRICES
- ▶ CUP DISCOUNT

Entering LARGE PRICES (Single Cup) or REGULAR PRICE provides access to a list of drinks with corresponding prices. For Large drink, the price of a displayed drink can be changed by pressing ENTER, altering the value shown, and pressing ENTER again.

NOTE: CUP DISCOUNT

Entering CUP DISCOUNT allows the programmer to set a discount for using 'own' cup or mug. The value entered here is deducted from the normal price of a drink when there is no requirement for a dispensed disposable cup.

## **INHIBIT DRINK**

Entering INHIBIT DRINK provides access to a sub-menu of drinks. The status of a displayed drink can be changed by pressing ENTER, altering the status by using the UP or DOWN keys, and pressing ENTER again. For example, COFFEE: STATUS=ON, makes coffee available for vending.

## **ALTER DRINK NAME**

The ALTER DRINK NAME menu allows the name displayed when a particular drink is selected to be changed to one of a number or pre-defined alternatives.

To avoid confusion the drink retains its original name as this submenu. The alternative name will be used to reference that selection for all other display and audit activities. The reason for retaining the original reference to the name in this submenu is that for example it could be that both drinks are to be CHOCOLATE temporarily. Once the VANILLA CAPP. name has been changed to CHOCOLATE it would not be possible to tell the altered drink from the existing one when it came time to change it back again.

The list of alternative drink names is as follows:

PREMIUM COFFEE	SOUP	BEEF SOUP
INSTANT COFFEE	WHIPPED COFFEE	TOMATO SOUP
LG COFFEE	COFFEE	VEG. SOUP
FD COFFEE	CHICKEN SOUP	CHOC-O-CINO
FRESH COFFEE	EXPRESSO X2	ALMOND AMERETTO (Rev38)
GROUND COFFEE	CAFÉ CREAME	HAZELNUT CAPPUCC (Rev38)
CHAI LATTE	ESPRESCHOCO	WHITE CHOC CARAMEL (Rev38)
TOFFEE CAPP	CAFÉ MOCHA	COLUMBIAN COFFEE (Rev38)
VANILLA CAPP	MUSHROOM SOUP	CARAMEL LATTE (Rev38)
LEMON TEA	CAPPUCCINO	ARAMEL CAPPUCC (Rev38)
		MOCA (Rev38)

Note: Changing a drinks name does not affect the actual parameters that control the drink. It only affects the name displayed when the selection is chosen or audited. If the name of the chocolate selection is changed to VANILLA CAPP, the chocolate ingredient motor, valves, and mixer will still run while the selection is taken.

### TIMED ACTIVITIES

The TIMED ACTIVITIES option allows the controller to be set to operate features on a timed basis. The timed features currently available are as follows:

- (a) FREE – drink prices revert to FREE at designated times/days
- (b) FLUSH – the soluble stations are flushed/rinsed with hot water
- (c) SHUTDOWN –the machine becomes inactive at the designated times/days
- (d) UNUSED – timed activity slot not in use
- (e) FL BREWER – The coffee Brewer is flushed/rinsed at the designated times/days
- (f) ECONOMY – causes the machine to temporarily shut-down until a drink is requested. The water in the boiler is maintained at a reduced temperature and a message prompting potential users to press start and so cause the machine to heat and return to operation. After a period of inactivity the machine returns to the low power mode.
- (g) REDUCED (Rev 42) – When operating in Single Cup mode (Large) a DISCOUNT feature can be programmed, during the designated times/days the 'REGULAR' price values are used

Entering TIMED ACTIVITIES provides access to a sub-menu consisting of ten timed activities. Two types of timing routine, Daily and Block, are available for each activity.

- (a) Daily

DAILY 0930 1730  
MON>FRI REDUCED

The above display describes a timed activity where, between 9:30am and 5:30pm, Monday to Friday, the machine operates in a reduced price mode.

- (b) Block

BLOCK 0930 MON>  
1730 FRI REDUCED

The above display describes a timed activity where, between 9:30am on Monday and 5:30pm on Friday, the machine operates continually in the reduced prices mode.

When entering a FLUSH state into a daily routine, a comma will appear between the start and end times, indicating that flushing will occur at the two specified times and not between them. Where only one SELF CLEAN per day is required, the time entered in the second slot should be 1 minute later than the first. If both times entered are the same, flushing may not take place.

Note: The FLUSH state **must not** be entered in a block routine.

The displayed activity can be changed by altering the data using the LEFT, RIGHT, UP and DOWN keys. With the correct data entered, the ENTER key is pressed to move to the next activity or ESC (escape) pressed to leave.

## TEMPERATURE SETTINGS

Entering TEMP SETTINGS provides access to the following sub-menu:

- ▶ DESIRED TEMP – allows the desired water heater temperature to be set.
- ▶ MINIMUM TEMPERATURE – allows the minimum temperature at which vending may commence to be set.

The above values are set in degrees Fahrenheit. The minimum possible temperature the control system can measure is 135°F (57°C), and it is not possible to set a desired temperature below this value. The value read by the analog to digital converter on the control board corresponding to the temperature set is displayed in parenthesis next to the °C value.

## OUTPUT TEST

The OUTPUT TEST allows any of the output devices to be turned on and off to aid with diagnostics. On entering output test, the display will show the device name, a prompt indicating that ↑↓ and ENTER keys are active, and a number indicating the position of the device in the list. The arrow keys are used to scroll through the list of devices while the ENTER key will activate and de-activate the device.

Note 1: It should be noted that some specific devices specifically the SSR, Cup Spiral Motor and the Inlet Valves may not respond as anticipated to OUTPUT TEST. The software controlling these devices is constantly running and will quickly override the control action of the output test. The output test function for the dispense arm is another special case. If either of the dispense arm actuators (DISPENSE ARM or DISP. ARM FORWARD) is invoked in output test, the arm will advance to ready to vend position, and then return to the home position.

Note 2: The output test function will not work if the engineers program was entered when the machine was powered up with the ENG LINK in place. See section 3 paragraph 4.

## INPUT TEST

The INPUT TEST function allows the state of the control board input signals to be examined. The input test menu is common to both versions of the Hot Beverage Merchandiser line and as such contains references to all possible input devices. The state of brewer position index inputs will be visible even if the brewers themselves are not fitted on a particular version.

On entering INPUT TEST, the display will show the device name of the first device in the list and logical state associated with the condition of its input. That is to say the meaning of the state of the input is displayed rather than a simple high or low value. Thus the values displayed for the waste probe are WET or DRY. The screen will dynamically reflect the condition of the input. The ↑↓ keys are used to step through each input in turn. The following input signals can be examined:

INPUT DEVICE	STATE1	STATE2
Coffee brewer index	CBREWER HOME	CBREWER NOT HOME
	CUPS AVAILABLE	CUPS NOT AVAILABLE
	CUP DROP IN POS	CUP DROP OUT POS
Dispense arm 'forward-ready-to-Vend position' micro switch	IN V POS	NOT IN V POS
Dispense arm 'HOME position' micro switch	ARM NOT HOME	DISP ARM HOME
Boiler level probe	BOILER IS WET	BOILER IS DRY
Waste bucket probe	WASTE IS WET	WASTE IS DRY
User cup sensor	CUPSNS:NO CUP	CUPSNS: CUP PRES
Brewer pressure switch	NO PRESSURE	PRESSURE
Jug switch	0 (Normal)	1 (jug or free)
Free input (J6 pin 13)	OFF	ON

Security (J6 pin 10)	OFF	ON
----------------------	-----	----

## SET PRODUCT CONSTANTS

The Hot Beverage Merchandiser control system maintains a counter for the amount of each ingredient consumed. For these counters to work correctly, the throw rate in grams per second actually dispensed from each ingredients canister must be input. One way to determine the correct value is to catch the ingredient dispensed during ten vends of a particular type and then divide the weight of ingredients so dispensed by the auger run time figures set for that vend. For this to work all scale factors must be set to 100.

If the ingredient counters are not required this facility can safely be ignored. The values entered are for audit purposes only and do not affect the drink formulations or machine operation in any way.

## MACHINE STATUS

Entering MACHINE STATUS provides access to the status of the following machine features.

- ▶ TEMP STATUS
- ▶ MEMORY USAGE\*
- ▶ I<sup>2</sup>C HEALTH
- ▶ SOFTWARE VERSION

### Temp Status

The display provides information relating to the heater control circuit. A power (PWR) level value and a graphical representation of the drive waveform to the heater are displayed. The temperature reading in degrees Fahrenheit derived from the thermistor probe in the water boiler is displayed along with the analog-to-digital converter value from which the temperature was calculated in parenthesis.

### I<sup>2</sup>C Health

This display provides information relating to the I<sup>2</sup>C serial link between the Controller and RIO Boards. A percentage "health" reading is given, indicating the success rate of communication of the link. A reading of less than 100% may indicate the presence of electrical noise. The number of negative acknowledgements (NACKS) is also recorded.

### Software Version

These displays indicate the version of the software installed on the Controller Board. (Program + EPROM = Firmware). The firmware version US-WIT-XX should be quoted when seeking advice.

## SET DRY VENDS

Entering SET DRY VENDS provides access to the following sub-menu:

### Vends Are Wet

All vends are dispensed with water as normal.

### Vends Are Dry

All vends are dispensed without water. This allows ingredients to be weighed. If a multi-ingredient drink is selected, only those ingredients will be vended.

## SERIAL NUMBER

Entering SERIAL NUMBER accesses the following sub-menu:

M/C Serial Number

The machine serial number consists of 8 digits and identifies the machine on audit trails.

M/C Audit Number

The machine audit number indicates the number of audits carried out to date.

## CONFIGURE MACHINE

Entering CONFIGURE M/C provides access to the following machine configuration sub-menu headings:

### GENERAL SETTINGS

The GENERAL SETTINGS menu provides access to a number of diverse parameters controlling machine operation that do not naturally group with any of the other control variables.

Parameter	Possible Values
SILENT KEYS	0 (default) – Sounds a beep. 1 – Keys are silent.
TOKEN ONLY	0 (default) – Messages appropriate to coins/card system or free. 1 – Messages appropriate to token only operation.
CHIPPER/CHIPKNIP	1 (default) – Suppress credit display if just card system fitted. 0 – Normal display of credit.
FLUSH ALARM	0 (default) – Sound loud siren while flushing. 1 – Sound siren quietly while flushing.
WATER SHOT START	0 (default) – Time after a fresh coffee dispense cycle ends that a grout clearing water shot starts. Consult factory before changing.
WATER SHOT DUR	0 (default) – Duration in 1/100 seconds that the water shot described above lasts. Consult factory before changing.
EARLY WATER SHOT DUR	15 (default) – Time in 1/10 seconds for the duration of the water shot before start of second air pump sequence
BELT WARN TIME	700 (default) – Time, in 1/100 seconds, after the pressure sensor should have reported the coffee brew chamber depressurized but has not, that a “New filter belt” warning is displayed.
BELT FAULT TIME	2000 (default) – Time, in 1/100 seconds, after the pressure sensor should have reported the coffee brew chamber depressurized but has not, that a “New filter belt” fault occurs.
ROTATION LIMIT	100 (default) – Time, in 1/100 seconds, after the pressure sensor should have reported the coffee brew chamber depressurized but has not, that a flag is set to perform an extra rotation of the brewer at the end of the next brewer drink cycle.
NO BELT WARNING	1 (default) - Do not display a message on the LCD when the filter needs changing. 0 – Display a message on the LCD when the filter needs changing.
ENG MODE TIMEOUT	0 (default) – Do not automatically exit engineer’s mode. Factory default. 30 – Time in 1/10 seconds after which, if no key is pressed exit from the engineers program will commence.
MAX EXTRA CUPS	2 (default) – Number of retries at dispensing a cup before a long delay until next cup occurs to deter theft.
SIMCARD LOCATION	0 (default) J4 - Location of attached smart memory (simcard) to save configuration data. J6 - Location of attached smart memory (simcard) to save configuration data.
CURRENCY	3 (default) – Controls The symbol printed on the LCD before monetary values. € \$ £ etc.
FREE INPUT	0 (default) – Disable free input on J6 pin 13. 1 – Enable free input on J6 pin 13. (Disable/Enable exist because in the event of static damage machine can continue operation if this input is ignored)
WINNER FREQUENCY	0 (default) – Winner Feature disabled 1 to 99999 – will initiate a ‘winner/free’ vend at the designated interval <b>Note: Will only work with cash vends</b>
SECURITY INPUT	0 (default) – Disable security input on J6 pin 10. 1 – Enable security input on J6 pin 10.

	(Disable/Enable exist because in the event of static damage machine can continue operation if this input is ignored. Can be unrecoverable if set when damage has already occurred.)
BREWER WATER CAP	950 ((default) Maximum open time for brewer water valve 1/10s second. Stops the operator putting too much water in the brewer (if it is set correctly).
BREWER EXCESS FAC	10 (default) This is a factor by which any excess water (>950) will be compensated by, i.e. the difference in the flow rates between 'Coffee Valve' and 'Hot Water' Valve.
BREWER ING. CAP	300 (default) – Maximum run time for coffee motor 1/10s second. Stops the operator putting too much coffee in the brewer (if it is set correctly).
TEMP IN CELSIUS	0 (default) = Fahrenheit 1 = Celsius
REGULAR SCALING	100 (default) – When you press for regular you get the regular drink with this scale factor applied to its settings. This is now somewhat redundant and should be left at the value (170). Changes are best done to the actual drink settings.
LARGE SCALING	100 (default) – When you press for large you get the large drink with this scale factor applied to its settings. This is now somewhat redundant and should be left at the value (170). Changes are best done to the actual drink settings.

### SET DRINK SIZES

There are 3 possible size settings to choose from:

- 1) LARGE – This is the normal single cup setting for a single volume fill
- 2) REGULAR + LARGE – this is the dual-fill setting that offers to fill volumes (100% & 66%) at two different prices
- 3) REGULAR – not used

### SET MACHINE TYPE

The SET MACHINE TYPE menu provides the means by which the control board software is configured to produce the desired menu and work with the appropriate combination of brewers and whippers present in the machine. This operation must be carried out when fitting a new or replacement board.

On selecting this option, the display will change to one of the following form:

MACHINE TYPE    # nn ABCD
------------------------------

Where 'ABCD' is a description of the machine configuration and #nn is the number of the configuration for reference purposes. The ↑↓ keys are used to scroll up/down the list of possible options. Pressing ENTER selects the new configuration. On completion, the screen reverts to the SET MACHINE TYPE menu. The following table contains an explanation of the abbreviations and reference numbers used.

ABBREVIATION	TYPE #	NO:	MODEL
<b>SFBC</b>	<b>00</b>	<b>1</b>	<b>Single Fresh Brew Coffee</b>
SFBC +CHLR	01	2	Not Used
<b>INST</b>	<b>02</b>	<b>3</b>	<b>Freeze Dried/Soluble</b>
INST +CHLR	03	4	Not Used
INST E	04	5	Not Used
INST E + CHLR	05	6	Not Used
<b>BTC</b>	<b>06</b>	<b>7</b>	<b>Bean To Cup (with Grinder)</b>
BTC +CHLR	07	8	Not Used

**NOTE: Care should be exercised when programming this option as all previous settings will be lost.**

**Table 1. Machine Configuration Matrix**

KEY	Config No.	Coffee	Tea	Decaf Coffee	Espresso	Cappuccino	Cafe Latte	Moccaccino	Chocolate	Hot Water	Vanilla Cappuccino	Toffee Cappuccino
# = Bean to Cup ◆ = Fresh brew coffee • = instant coffee/tea												
BEAN TO CUP	7	#	•	•	#	#	#	#	•	•	•	•
SFBC	1	◆	•	◆	◆	◆	◆	◆	•	•	•	•
SOLUBLE/INSTANT	3	•	•	•	•	•	•	•	•	•	•	•

**SET CUP SIZE**

Use the ↑↓ keys (2 or 8) to scroll through the list of size options, when the desired size is displayed press the '0' key to select/confirm.

There are 5 sizes to choose from:-

- 1) 7oz
- 2) 8.25oz
- 3) 9oz
- 4) 10oz
- 5) 12oz (factory default setting)

**SET CASH SYSTEM**

This option in this sub-menu allows the type of credit device to be selected.

Display Title	Description
MDB PROTOCOL	Used for all standard MDB coin changers, bill validators & cashless systems
MDB (ZIP VARIANT)	Used European ZIP cashless system & <b>most US Credit Card Systems</b>
MDB SLVE	Used when the coffee machine is to be a standard MDB Universal Satellite Device i.e. payment is made in its host machine
MDB SLAVE (SM6)	Used when the coffee machine is to be a MDB Universal Satellite Device where payment is made in its Snack Mart VI host machine
NO SYSTEM	Used when the machine has no payment system i.e. it is set for permanent 'FREE VEND'
DIGICARD	Not Used

**HARDWARE SETTINGS**

This sub-menu allows some machine components to be disabled to allow limited functionality to be restored in the event of a failure. For example in the event that one of the cup sensor PCBs fails, it is possible to inform the control system that these are not fitted. Likewise in the event of a brewer failure setting the COFFEE BREWER to NO will allow any selections not reliant on the brewer to operate. While all possible system components are visible in this sub-menu, irrespective of the machine's configuration, it is only meaningful to ENABLE components that actually exist in the machine. Thus it makes no sense to set TEA BREWER to YES on all-instant machine and indeed will result in an IO MAPPING ERROR.

Parameter	Function
CUP SENSORS	Enable/disable user cup sensors. Default is YES sensors fitted.
DISPENSE ARM	Enable moving the dispense head. Default is YES. Can be usefully disabled only for diagnostics. The machine cannot operate with this item deselected.

TEA BREWER	NOT USED
COFFEE BREWER	Enable Coffee Brewer – Default for double fresh brew configurations is YES. Instant and single fresh brew configurations NO.
COLD UNIT	NOT USED
NO CUP MECH	Allows a machine to operate without a cup unit fitted i.e. reliant on users providing their own cups. Default is NO i.e. there is a cup mechanism fitted.
VEND DOOR	YES – Default setting which enables the automatic vend door. NO – Disables the automatic vend door.

### **MDB CONFIG**

This menu provides the means to modify parameters related to MDB peripherals connected to the machine. At present these are limited to those associated with a change giving mechanism. However as support for additional peripheral is added so additional settings will be added as appropriate.

The following table lists the sub-menus and parameters that are configurable:

<b>Parameter</b>	<b>Function</b>
EXACT CHANG LIM	\$2.50 (default) – This monetary value represents the value of coins remaining in the change tubes below which the EXACT CHANGE message is displayed. <b>NOTE:</b> For the audit system to work correctly it is important that all coins are inserted via the coin insert slot instead of being placed directly in the change tubes.
MDB USD ADDRESS	40 (default)
VALIDATOR ESCROW	000000000011110 (Rev 42_default) – Will stack a \$1 bill and hold others accepted in escrow
VEND BEFORE CHANGE	NO (default) – Possible values are YES and NO. When set to YES, change will not be given until a vend cycle has taken place.
CHANGER MODE	SINGLE VEND (default) - Possible values are SINGLE VEND and MULTI VEND. When set to MULTI VEND, change will only be paid in response to depression of the escrow lever. When set to SINGLE VEND, change will be given automatically following the vend cycle or in response to depression of the escrow lever.
MASK AUTO CONFIG	Runs a procedure to carry out automatic configuration of the coin mechanism acceptance masks.
EXACT CHG BILLS	000000000000000 (default) - Specifies which paper currency (bill or notes) the bill validator will accept when there is no change available
NORMAL BILLS	000000000011111 (Rev 42_default) - Specifies which bill/s or note/s the validator will accept (default \$1, 5 & 10) with appropriate change available in the tubes
EXACT CHG COINS	000000000000111 (default) - This variable controls which coins are accepted in circumstances where the exact change message would be displayed. The MDB protocol provides for up to 16 coins. For the purposes of enabling or disabling acceptance, the coins are represented by the letters A through P with A being the least value coin. The acceptance status of each coin is shown by a 1 or 0 below the corresponding letter. One indicates acceptance (1=accept) and zero indicates rejection (0=reject). Default will accept 5c, 10c & 25c coins. <div style="border: 1px solid black; padding: 5px; margin: 10px auto; width: fit-content;">           PONMLKJIHGFCBA            000000000000111         </div> <b>Note: Some Coin Changers have \$1 change tubes, in which case channel 'D' will require enabling to accept it/them.</b>

Parameter	Function
NORMAL COINS	<p>000000000001111 (default) - This variable controls which of the coins that an attached changer is programmed to accept should actually be accepted in normal operation i.e. other than exact change mode. For the purpose of changing the coins to be accepted the procedure is the same as for Enable Coins Exact Change above.</p> <div style="border: 1px solid black; padding: 5px; margin: 10px auto; width: fit-content;"> <p>PONMLKJIHGFCBA 000000000001111</p> </div> <p><b>Note: Some Coin Changers have \$1 change tube/s and are capable of accepting \$2 coins, in which case channels 'E' &amp; 'F' or more will require enabling to accept it/them.</b></p>
CHANGE VALID DUR (Rev 42)	<p>The duration which change is preserved when it is not possible to pay back the allowable amount of change (Max. Change parameter). A range of values between 0 – 255 minutes can be programmed.</p> <p><b>Note: programmed values between 0 – 5 are ignored i.e. credit will remain indefinitely</b></p>
MAX CHANGE GIVEN (Rev 42)	<p>The value set in the field will determine the maximum amount of change that the machine will payout. A value of zero disables the feature.</p> <p>Following a vend if the remaining value of credit is greater than the MAX CHANGE value set then no change will not be paid out. Further vends can then be taken to bring the credit value down ≤ the MAX CHANGE value, then the change will be automatically paid out (single vend mode).</p> <p><b>Note:</b></p> <ol style="list-style-type: none"> <li>1. Any remaining credit will be retained for the period set in the CHANGE VALID DURATION (see above).</li> <li>2. It is recommended that a sign is posted on the machine warning consumers that there is a change limit in operation</li> </ol>
MAX CREDIT	<p>\$2.50 (default) – This monetary value defines the maximum amount that can be accepted by the mechanism.</p>

## EVA-DTS CONFIG

The EVA-DTS configuration menu provides the means to modify parameters controlling the format and method of auditing the machine. At the time of writing, the machine supports EVA-DTS audit via DDCMP protocol IRDA transceiver or Direct connect. The sub-menus of this menu are:

### PREVIOUS AUDIT

On selecting this option, the LCD screen will show a screen detailing the time and date of the last audit. The layout of the screen is as shown below:

NO:XXXX ID:YYYYYY DD/MM/YY 00:00
-------------------------------------

Where

- ▶ XXXX represents the audit number maintained by the vending machine and incremented after each audit.
- ▶ YYYYYY represents the data carrier ID.
- ▶ DD/MM/YY is the date the audit took place.
- ▶ hh:mm is the time at which the audit took place.

### METHOD OF AUDIT

Parameter	Function
AUDIT METHOD	Possible values are: DDCMP - selects infrared or direct connect audit. DISABLED - turns off the audit system. DEX-UCS selects a DEX audit system.

### AUDIT CONFIG

Parameter	Function
SECURITY CODE	Default 0 – Any data carrier may audit the machine. The code is set by a data carrier. Once set by a carrier only a carrier with the appropriate code may access the machine.
PASS CODE	Default 0 – Any data carrier may audit the machine. The code is set by a data carrier. Once set by a carrier, only a carrier with the appropriate code may access the machine.
STATION ADDRESS	Default 7 – Identifies the unit as a VMC for audit purposes.

## PRODUCT CODES

EVA DTS product code for each selection can be set by the operator if they don't like the default values.

### OPERATOR CODE

Use this menu to change the operator's access code. Also refer to PROGRAMMING on page 26.

### MANAGER CODE

Use this menu to change the manager's access code. Also refer to PROGRAMMING on page 26.

### ENGINEER CODE

Use this menu to change the engineer's access code. Also refer to PROGRAMMING on page 26.

### FREE DRINK CODE

Use this menu to create a free drink code which can be used to obtain a 'FREE' vend without having to insert money or opening the door to use the internal keypad. While the machine is in normal operation, press the 9 button twice on the external keypad followed by the four (4) digit code.

## EDIT DRINK MAP

The Edit Drink map facility allows alternative drink recipes to be assigned to the selection buttons. For example the hot Tea selection can be substituted by a Chai Tea/Latte where there is no requirement for sugar & lightener additives. In this example the procedure is as follows:

1. Press the PROG key on the internal keypad
2. Go to the external keypad
3. Enter 4444
4. Scroll down using the '8' key to menu heading EDIT DRINK MAP
5. Display shows: DRINK NUMBER 1:  
COFFEE
6. Scroll up using the '2' key to:  
DRINK NUMBER 3:  
TEA
7. Press 0 (ENTER)
8. The display shows: TEA  
↑↓ ENTER OR ESC
9. Scroll down using the '8' key to CHAI LATTE
10. Press 0 (ENTER)
11. The display shows: DRINK NUMBER 3:  
CHAI LATTE
12. Press # (ESC)
13. The display shows: COMMIT CHANGES  
ENTER=YES, ESC=NO
14. Press 0 (ENTER)
15. The display momentarily shows: INITIALISING DEFAULTS
16. Make any further programming changes to set prices, set cup size etc. etc.

### IMPORTANT NOTES:

1. When making any changes to the drink map, all other configuration settings will default to factory values. **ALWAYS MAKE ANY DRINK MAP CHANGES FIRST.**
2. In addition to making the programming recipe substitution the TEA station will also require a whipper motor adding, see details on Pg XX (At foot of Chai Tea recipe chart).

## CARD ACTIONS

Available only if a smart card is inserted in the smart card reader. Allows config/audit data to be saved or read from the card.

Display Title	Description
INSERT CARD	No card present in reader unit, a prompt to insert a card
SAVE STRINGS	To download & save all the custom messages stored in the machine's controller memory to the smart card
SAVE EVENTS	To download & save all the TIMED ACTIVITIES stored in the machine's controller memory to the smart card
SAVE PRICES	To download & save all the DRINK PRICES stored in the machine's controller memory to the smart card
SAVE CONFIG	To download & save all the CONFIGURATION DATA stored in the machine's controller memory to the smart card
SAVE MACHINE	To download & save <b>ALL</b> the settings stored in the machine's controller memory to the smart card
DELETE DATA	To erase any previously stored data from the smart card
FORMAT CARD	Erases any previously stored data and reformats the smart card ready to receive data stored in the machine's controller memory. This is also required to format a new smart card before it can be used

LOAD STRINGS	To upload & save all the DRINK PRICES stored on the smart card to the machine's controller memory
LOAD EVENTS	To upload & save all the TIMED ACTIVITIES stored on the smart card to the machine's controller memory
LOAD PRICES	To upload & save all the DRINK PRICES stored on the smart card to the machine's controller memory
LOAD CONFIG	To upload & save all the CONFIGURATION DATA stored on the smart card to the machine's controller memory
LOAD MACHINE	To upload & save <b>ALL</b> the machine settings stored on the smart card to the machine's controller memory

**NOTE:** The 'LOAD' options will not appear unless the relevant data field has already been downloaded/stored on the smart card

## EDITABLE TEXT

1. The Geneva provides two user definable frames of text. These 'frames' are designated the 'Select Message' and the 'Error Message' respectively, are displayed at intervals whenever the machine is displaying the select drink or error screens respectively. Each message consists of 2 lines of 16 characters.

For example Standby Message could alternate between:

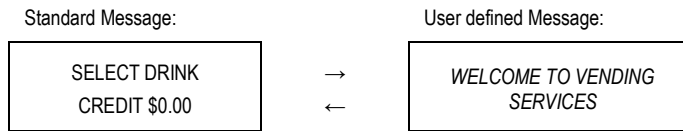

For example Out of Service Message could alternate between:

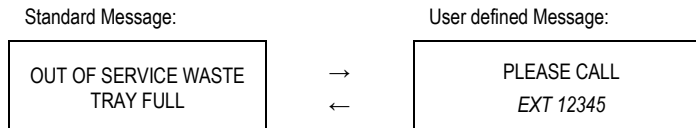

2. The EDITABLE TEXT menu contains the following sub menus, which can be accessed using the ↑↓ keys:

- a. Edit Select Msg

Allows the programmer to change the line of optional text displayed in the 'select drink' state. On pressing ENTER the display will change to one of the form shown below:

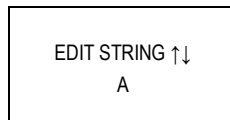

The ↑↓ keys are used to scroll through the available characters. The ← → keys can be used to move the cursor along the line of text.

**NOTE: When the correct text has been entered, the ENTER key must be pressed to confirm the changes. Pressing the ESCAPE discards them.**

- b. Edit Error Msg

Allows the programmer to change the optional text displayed when the machine is in a fault condition.

- c. Erase Select Msg

Allows the programmer to clear the optional select message text.

- d. Erase Error Msg

Allow the programmer to clear the line of optional Error message text.

## DEPRESSURIZE COFFEE BREWER

In the event that the coffee brewer remains in a pressurized state and you wish to quickly depressurize the air remaining in the chamber, there is a facility which overrides the safety pressure switch. The sequence to do this is as follows:-

With DEPRESSURISE CBR showing on the display, press ENTER (0)

The display will show either:

COFFEE BREWER NOT PRESSURISED – in which case powering the machine down/up will cycle the brewer home.

OR

IS BREWER COVER IN POSITION? – **This is a safety warning, opening the brewer under pressure will squirt any hot water & coffee grounds from the cylinder base! To proceed further confirmation is required by pressing ENTER (0) a 2<sup>nd</sup> time.**

After pressing the enter key the brewer motor will be switched ON for a moment which will advance the brewer to marginally release the cylinder from the filter platform seal, allowing the pressure to escape. This will be repeated until the pressure switch changes state when the sequence will stop.

To return the brewer to its home position power the machine DOWN for a few seconds then UP again.

## COFFEE BREWER

### COFFEE BREWER OPERATION

1. The coffee brewer motor is driven a little way to clamp the base of brewing chamber to the surface of the filter platform to seal. This position is determined by the index roller switch and the 2<sup>nd</sup> dwell in the cam.
2. Water & ground coffee are dispensed into top mixing bowl of brewer unit
3. After the water delivery stops, the brew/fusion delay time starts
4. At the end of the brew/fusion time, the brewer motor drives for a moment to lift the top plunger in to seal off the top of the brewer chamber. This position is determined by the index roller switch and the 3<sup>rd</sup> dwell in the cam.
5. The 1<sup>st</sup> stage of the air pump starts and runs for the programmed duration to pressurize the chamber and push the brewed coffee out and into the coffee whipper station
6. At the end of the 1<sup>st</sup> pumping stage there is a programmed delay, this is to allow the pressure to drop and for the coffee whipper chamber to empty (i.e. not to overflow)
7. At the end of the 1<sup>st</sup> delay phase the 2<sup>nd</sup> stage air pump starts, after approximately 1 second it should be possible to hear air pass through into the coffee whipper chamber, having pushed all of the liquid out of the chamber. The remaining pumping time will dry the spent coffee grinds.
8. At the conclusion of the 2<sup>nd</sup> pumping stage there is a further programmed delay, to further assist the drying process.
9. At the conclusion of the 2<sup>nd</sup> stage pump delay the air pressure switch is checked, if there is no pressure present, the brewer motor is switched ON to drive the brewer back to its home position, in the process the brew chamber will be lifted above the level of the spent coffee grounds and the filter belt is driven to remove/discard the grounds.

However, if air pressure is still present a waiting/time-out period is started, the pressure switch is then checked at 1 second intervals up to 20 seconds. This is to prevent the chamber opening under pressure and making a mess.

If the pressure subsides at any point up to the 20 seconds, the brewer motor will be switched ON to drive home as normal.

If air pressure is still present after 20 seconds, then the coffee brewer is put out of action, and COFFEE BREWER FAULT is displayed.

**A 'BREWER FAULT' condition can be reset by switching the machine OFF and back ON.**

However, if the cause of the pressure remaining is not remedied, then the fault condition will be reinstated at some earl point.

## BEAN TO CUP

### SET-UP

1. In the Engineers Programming Mode, the Bean To Cup configuration is set-up under the 'MACHINE TYPE' menu, which is a sub-menu of 'CONFIGURE MC', as follows:

ABBREVIATION	TYPE #	NO:	MODEL
<b>SFBC</b>	<b>00</b>	<b>1</b>	<b>Single Fresh Brew Coffee</b>
SFBC +CHLR	01	2	Not Used
<b>INST</b>	<b>02</b>	<b>3</b>	<b>Freeze Dried/Soluble</b>
INST +CHLR	03	4	Not Used
INST E	04	5	Not Used
INST E + CHLR	05	6	Not Used
<b>BTC</b>	<b>06</b>	<b>7</b>	<b>Bean To Cup (with Grinder)</b>
BTC +CHLR	07	8	Not Used

The MACHINE TYPE should be set to 'BTC Type #: 06/No. 7'.

2. **The Bean** - Use a mild/medium roast 100% Arabica or Columbian whole bean coffee. Be sure to avoid using an oily bean/blend as this will clog the grinder and the ground coffee will not flow freely. The Darker/higher roast beans tend to be oily in nature.

#### IMPORTANT

In the process of making a vended cup of bean to cup coffee there is a limited time in which to deliver the required amount of ground coffee into the brewer. Beans & blends which have a lower bulk density will not be ground or pass through the grinder at the required rate, resulting in insufficient coffee to produce a good level of flavor. It is recommended that the whole bean coffee with a bulk density greater than 21lbs/cu ft is used. This will provide the optimum rate of ground coffee production.

3. The factory adjustment setting for the coffee grinder mills will be as shown below with the collar mark at the 9 o'clock position (this is a ¼ anti-clockwise turn of the collar from the fully closed position).

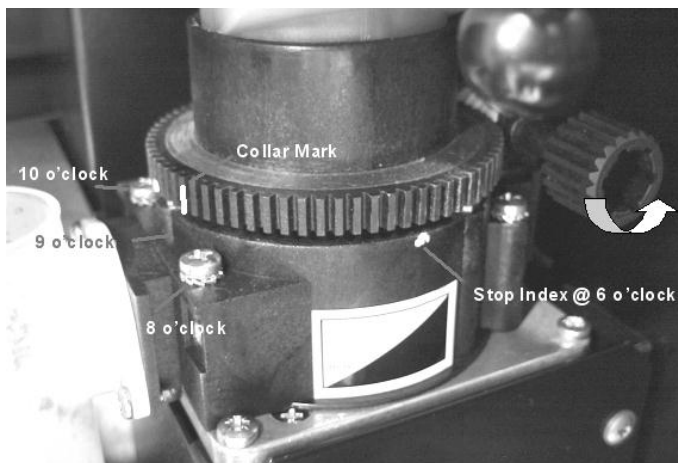

**BEAN TO CUP .... CONTD.**

4. Referring to the above recommendation regarding the bulk density of the beans, to set the most effective level of grind, the grinding mills should be adjusted to deliver approximately 2 grams per second. In most cases it is expected that this level of grind will be achieved when the collar mark is between the 8-10 o'clock positions i.e. between the 2 screw-heads shown below.
5. It is recommended that a serving of 0.0 -1.1g of ground coffee is delivered for each 1oz of water.
6. Do not attempt to throw/deliver more than 13 grams of coffee for a 10oz volume drink (12oz cup).

**Bean To Cup - Ingredient Canister Configuration**

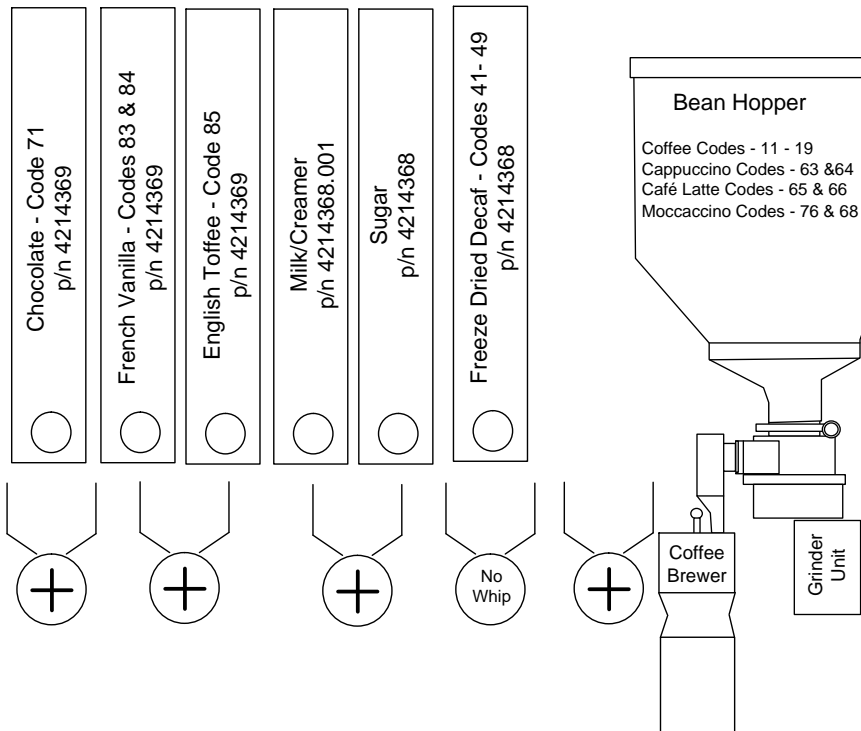

# BEAN GRINDER SCHEMATIC

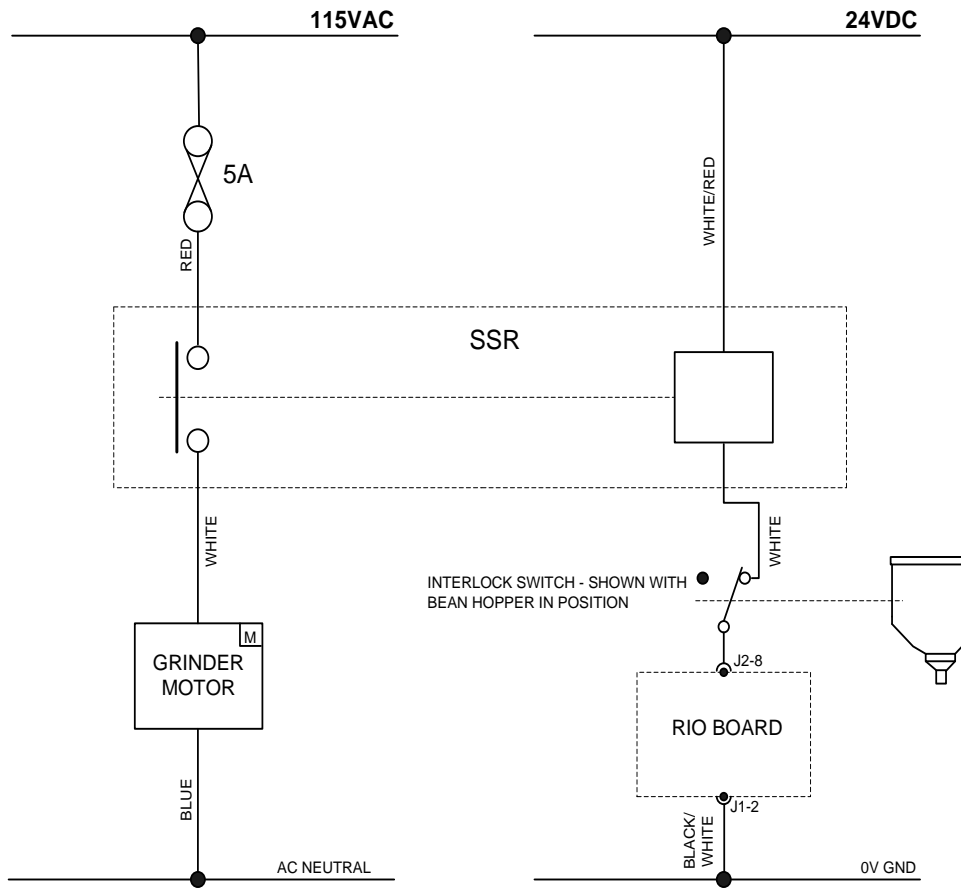

## TROUBLESHOOTING GUIDELINES

Problem	Symptom	Remedy
No Coffee	COFFEE BREWER FAULT displayed – Upon power-up the coffee brewer completes one cycle as normal and stops in home position	The brewer fault condition has been triggered by a 20 second time-out, indicating that the air pressure inside the brewer cylinder is remaining after the vend: 1. Filter Belt Blocked – Replace (p/n 4215265.001) 2. Coffee Grinds are too fine, replace with 17 grind or greater
		The air pressure switch is faulty and is not opening (normally operates to close switch at 4 psi) – Replace switch
	COFFEE BREWER FAULT displayed – Upon power-up the coffee brewer runs continuously for approximately 3 ¼ cycles and then stops off the home position	1. The brewer index switch has failed - replace 2. The signal is not present at J6 of the RIO board – Check wiring/terminals and rectify
No Coffee	Coffee Brewer is stalled and is full of coffee grinds	Check that the brewer carriage is pushed fully back and locked into position. Check that belt is being driven correctly by using the 'ADVANCE COFFEE BREWER' key on the internal keypad
		Coffee grinds are not being completely washed through the top mixing bowl. Flush to clear, then; 1. Check/adjust all coffee recipes to be sure the top chamber is rinsed clear 2. Is there a sufficient water swirl to clear the coffee – adjust or replace valve 3. If the water is unable to pass into the lower chamber quickly, then adjust the top seal in a downward direction by one half of a turn on the thread
		The filter belt is slipping – 1. Check that the belt tension bar is not in the 'relaxed' position. 2. If the belt is tensioned and is still slipping, replace the filter belt (pn 4215265.001) 3. See section below related to wet/sloppy grinds
		Coffee throw is too high, spent coffee grinds are left inside chamber when belt moves to clear, reduce throws to less than 13gms
Short level of Coffee in cup or Coffee Grounds in drink	The spent coffee grinds are wet/sloppy	Coffee belt is worn/choked, replace belt (Blue stitching pn 4215265.001 – 55 Micron)
		Seal at base of brewing cylinder is damaged causing leakage – replace cylinder
		Seal in filter platform damaged or missing causing leakage – replace seal/platform
		The air pump has failed, or is failing intermittently, no pressure being produced – replace air pump (check with end of little finger to see if pump is producing pressure at the bulkhead connection, using the OUTPUT TEST to run the pump)

Problem	Symptom	Remedy
Contd ..... Short level of Coffee in cup or Coffee Grounds in drink	When the chamber lifts towards the end of the vend cycle, water & coffee grinds come gushing out	The air pump is starting to fail, or is failing intermittently, insufficient pressure is being produced – replace air pump (check with end of little finger to see if pump is producing pressure at the bulkhead connection, using the OUTPUT TEST to run the pump)
		The water and grounds are not passing from the top mixing bowl into the main brewing chamber before it is sealed-off at the top, hence when the chamber lifts at the end of the cycle the remaining water gushes from the cylinder. Note: This can be intermittent. Relax the sealing rod adjustment by <u>ONE TURN ONLY</u> to lower the seal position thus allowing the Water/Grounds to pass through more easily.
		One of the air carrying tubes have come adrift – replace offending tube (check with end of little finger to see if pump is producing pressure at the bulkhead connection, use OUTPUT TEST to run the pump)
		Airway into cylinder is blocked with coffee grinds or similar, remove cylinder and check/clear airway with paper clip. Invert cylinder and fill with water and check that water flows freely from air inlet port.
		The rubber bellows joining the brewing cylinder sections is spilt causing leakage. Invert cylinder and fill with water to check for leaks whilst working bellows – replace cylinder assembly
Short level of Coffee	Water coming out of whipper funnel cap like a fountain/whale blow	Coffee canister empty, therefore water coming through too quickly – Fill canister
		Coffee whipper impellor too far forward on shaft blocking outlet due to being loose or not fitted correctly (flat not aligned) – replace impellor or fit correctly
<b>BEAN TO CUP:</b> The coffee is lacking flavor or 'weak'	Insufficient ground coffee dispensed The beans are oily which is slowing down the rate of delivery	Select a mild to medium roast bean to avoid an oily texture
	Insufficient ground coffee dispensed The beans are too big i.e. 0.394" (10mm) or larger.	Select a mild/medium roast 100% Arabica or Columbian whole bean coffee which has a bulk density of 21lbs/cu ft
	Insufficient ground coffee dispensed The milling faces of the stainless steel mills are worn (in normal operation they have a life of 50,000 vends)	Replace the grinding mills/grinder unit

## REPLACEMENT CONTROL BOARD SET-UP

The FMCU Control Board (p/n 4214454) used in the Hot Beverage Merchandiser utilizes static sensitive components. Precautions for handling static sensitive devices should be observed when handling this item.

The Hot Beverage Merchandiser control board is programmable on two levels. At the lowest level the board's Flash memory (firmware), can be reprogrammed to enable a wide range of different machines to be controlled. This level of programming requires a PC and special interface equipment and is essentially a factory/main base activity. The firmware programmed into a board can be read from the label fitted to the component side of the board or if placed in a functioning machine using the Machine Status menu. Please refer to section 3 paragraph K.

The Hot Beverage Merchandiser software versions will typically be of the form "US\_WIT\_XX". "US\_WIT" denotes the program and XX is a number defining the version. New versions will be generated to support customer specific configurations and behaviors. It is therefore important to check that the firmware programmed into a board is appropriate to the machine to which it is to be fitted, as older version may not support a particular machine type.

The second level of programming involves setting up the board to operate the correct predefined menu configuration for the machine to which it is fitted. This section details the procedure to achieve this:

1. Switch OFF machine
2. Place shorting jack across the 'ENG LINK'
3. Power-up, service mode is entered automatically ('INGREDIENT TIMES' displayed)
4. Press **2** (UP) or **8** (DOWN) on front keypad board repeatedly to reach "CONFIG MC"
5. Press **0** (ENTER) – "GENERAL SETTINGS"
6. Press **2** (DOWN) repeatedly to reach "SET MACHINE TYPE"
7. Press **0**
8. Select machine type required by pressing **2** (UP) or **8** (DOWN):

ABBREVIATION	TYPE #	NO:	MODEL
<b>SFBC</b>	<b>00</b>	<b>1</b>	<b>Single Fresh Brew Coffee</b>
SFBC +CHLR	01	2	Not Used
<b>INST</b>	<b>02</b>	<b>3</b>	<b>Freeze Dried/Soluble</b>
INST +CHLR	03	4	Not Used
INST E	04	5	Not Used
INST E + CHLR	05	6	Not Used
<b>BTC</b>	<b>06</b>	<b>7</b>	<b>Bean To Cup (with Grinder)</b>
BTC +CHLR	07	8	Not Used

9. Press **0** (ENTER) to confirm and wait for reinitializing process to complete
10. Select CUP SIZE required by pressing **2** (UP) or **8** (DOWN):
  - 7oz
  - 8½oz
  - 9oz
  - 12oz (FACTORY DEFAULT)
11. Press **0** (ENTER) to confirm
12. Press **#** repeatedly until "REMOVE ENGINEERS LINK" is shown on display
13. Switch OFF and remove the shorting jack and park on a single pin
14. Board is now initialized.
15. Re-enter programming mode and set the time & date, prices etc.

**NOTES:**

The contents of this publication are presented for informational purposes only, and while every effort has been made to ensure their accuracy, they are not to be construed as warranties or guarantees, express or implied, regarding the products or services described herein or their use or applicability. We reserve the right to modify or improve the designs or specifications of such products at any time without notice.



VendNet™  
165 North 10th Street  
Waukee, Iowa 50263  
United States of America



	USA & Canada	International
Service	<b>(800) 833-4411</b>	<b>(515) 274-3641</b>
Parts	<b>(888) 259-9965</b>	
Email	<b>vendnet@vendnetusa.com</b>	
Web Site	<b>www.vendnetusa.com</b>	